

Watson-Marlow 520DuS NEMA 4X SCADA pumps



Contents

1	Declaration of conformity	3	18.8	Flow units	44
2	Declaration of incorporation	3	18.9	Run time	45
3	Warranty	4	18.10	Outputs	46
4	When you unpack your pump	5	18.11	Remote stop	48
5	Information for returning pumps	6	18.12	Auto-restart	50
6	Peristaltic pumps - an overview	7	18.13	Set maximum speed	51
7	Safety notes	8	18.14	Backlight	51
8	Pump specifications	10	18.15	ROM	52
8.1	Dimensions	15	18.16	Language	52
9	Good pump installation practice	16	18.17	Defaults	53
9.1	General recommendations	16	18.18	Beep	53
9.2	Do's and do not's	16	18.19	Security code	54
10	Connecting to a power supply	18	18.20	Exit	55
11	Start-up check list	21	19	Pin-out details	55
12	Switching on for the first time	21	20	MemoDose	56
13	Switching on subsequently	23	20.1	Changing dosing speed	57
14	Manual operation	24	20.2	Footswitch operation with MemoDose	58
14.1	Keypad functions in manual mode	24	21	Exit	58
14.2	Keypad lock	27	22	Automatic control wiring	59
14.3	Keypad beep	27	22.1	520N module fitting	59
14.4	Manual operation and remote digital inputs and outputs	27	22.2	Wiring up	61
15	Main menu	28	22.3	Speed: analogue input 1	64
15.1	Keypad in menu screens	28	22.4	Scaling: analogue input 2	65
15.2	Main menu entry	29	22.5	Speed: analogue output	66
16	PIN-secure process protection	30	22.6	Run / stop input	67
17	Calibrate	31	22.7	Direction input	67
18	Setup	35	22.8	Auto / manual toggle	68
18.1	Trim	36	22.9	MemoDose input	68
18.2	Analogue	37	22.10	Leak detection input	68
18.3	Display	41	22.11	Outputs 1, 2, 3, 4	69
18.4	Pump number	42	22.12	RS485 input	70
18.5	Baud	42	23	Automatic control and operation	71
18.6	Stop bits	43	24	Network control and operation	74
18.7	Xon/Xoff	43	24.1	RS485 command strings	76
			25	Troubleshooting	77
			25.1	Error codes	78

26	Drive maintenance	79
27	Drive spares	79
28	The 520R, 520R2 and 520RE pumpheads	80
28.1	Pumphead fitting	81
29	520R and 520R2 commissioning	83
29.1	Opening the guard	83
29.2	520R and 520R2 tube loading	84
29.3	520RE: fitting the drain port	85
29.4	520RE Element loading	86
29.5	520RE Element connection	88
30	520R, 520R2 and 520RE maintenance	89
31	520R, 520R2 and 520RE rotor settings	90
32	Pumphead spares	91
33	Flow rates	92
34	Tubing and element part numbers	100
35	520 series pumping accessories	103
36	Trademarks	104
37	Patient-connected applications	104
38	Publication history	104
39	Decontamination certificate	105

1 Declaration of conformity



This declaration was issued for Watson-Marlow 520DuS pumps on February 1, 2004. When this pump unit is used as a stand-alone pump it complies with: Machinery Directive 2006/42/EC, EMC Directive 2004/108/EC.



This pump is ETL listed: ETL control number 3050250. Cert to CAN/CSA std C22.2 No 1010-92. Conforms to UL std 61010A-1, April 30, 2002.

See 8 *Pump specifications*.

2 Declaration of incorporation

When this pump unit is to be installed into a machine or is to be assembled with other machines for installations, it must not be put into service until the relevant machinery has been declared in conformity with the Machinery Directive 2006/42/EC. See 8 *Pump specifications*.

Responsible person: David Cole, Managing Director, Watson-Marlow Limited, Falmouth, Cornwall TR11 4RU, England. Telephone +44 (0) 1326 370370 Fax +44 (0) 1326 376009.

The information in this user guide is believed to be correct at the time of publication. However, Watson-Marlow Limited accepts no liability for errors or omissions. Watson-Marlow Bredel has a policy of continuous product improvement, and reserves the right to alter specifications without notice. This manual is intended for use only with the pump it was issued with. Earlier or later models may differ. The most up-to-date manuals appear on the Watson-Marlow website: <http://www.watson-marlow.com>

3 Five year warranty

520 cased pumps, 620 cased pumps and 720 cased pumps

For any 520, 620 or 720 cased pump purchased after 1 January 2007, Watson-Marlow Limited ("Watson-Marlow") warrants, subject to the conditions and exceptions below, through either Watson-Marlow, its subsidiaries, or its authorised distributors, to repair or replace free of charge, any part of the product which fails within five years of the day of manufacture of the product. Such failure must have occurred because of defect in material or workmanship and not as a result of operation of the product other than in normal operation as defined in this pump manual.

Watson-Marlow shall not be liable for any loss, damage, or expense directly or indirectly related to or arising out of the use of its products, including damage or injury caused to other products, machinery, buildings, or property, and Watson-Marlow shall not be liable for consequential damages, including, without limitation, lost profits, loss of time, inconvenience, loss of product being pumped, and loss of production. This warranty does not obligate Watson-Marlow to bear any costs of removal, installation, transportation, or other charges which may arise in connection with a warranty claim.

Conditions of and specific exceptions to the above warranty are:

Conditions

- Products must be returned by pre-arrangement, carriage-paid, to Watson-Marlow, or a Watson-Marlow approved service centre.
- All repairs or modifications must have been made by Watson-Marlow Limited, or a Watson-Marlow approved service centre or with the express permission of Watson-Marlow.
- Warranties purporting to be on behalf of Watson-Marlow made by any person, including representatives of Watson-Marlow, its subsidiaries, or its distributors, which do not accord with the terms of this warranty shall not be binding upon Watson-Marlow unless expressly approved in writing by a Director or Manager of Watson-Marlow.

Exceptions

- The warranty shall not apply to repairs or service necessitated by normal wear and tear or for lack of reasonable and proper maintenance.
- All tubing and pumping elements as consumable items are excluded.
- Products which, in the judgment of Watson-Marlow, have been abused, misused, or subjected to malicious or accidental damage or neglect are excluded.
- Electrical surge as a cause of failure is excluded.
- Chemical attack is excluded
- All pumphead rollers are excluded.
- The 620R family of pumpheads are excluded from all warranty when pumping above 2 bar while above 165rpm.
- Pumpheads from the 313/314 and the Microcassette ranges and any 701 extension pumpheads are excluded and retain their one-year standard pumphead warranty. The drive they are attached to is subject to the five-year warranty as set out here.
- Ancillaries such as leak detectors are excluded.

4 When you unpack your pump

Unpack all parts carefully, retaining the packaging until you are sure all components are present and in good order. Check against the components supplied lists, below.

Packaging disposal

Dispose of packaging materials safely, and in accordance with regulations in your area. Pay particular attention to the expanded polystyrene shockproof shells. The outer carton is made of corrugated cardboard and can be recycled.

Inspection

Check that all components are present. Inspect components for damage in transit. If anything is missing or damaged, contact your distributor immediately.

Components supplied (520DuS pump, NEMA 4X SCADA models)



- The 520DuS pump drive unit fitted with:
 - 520R2 or other pumphead (see 8 *Pump specifications*) if specified as a pump
 - A 520N SCADA module providing pump ingress protection to IP66, NEMA 4X.
Note: the module is attached for transit, but must be removed to allow wiring up, voltage selection and fuse inspection and then re-affixed before the pump is operated.
 - The designated mains power lead for your pump
- PC-readable CDROM containing these operating instructions
- Quick Start manual

Note: Some versions of this product will include components different from those listed above. Check against your purchase order.

Storage

This product has an extended shelf life. However, care should be taken after storage to ensure that all parts function correctly. Users should be aware that the pump contains a battery with an unused life of seven years. Long-term storage is not recommended for peristaltic pump tubing. Please observe the storage recommendations and use-by dates which apply to tubing you may wish to bring into service after storage.

5 Information for returning pumps

Equipment which has been contaminated with, or exposed to, body fluids, toxic chemicals or any other substance hazardous to health must be decontaminated before it is returned to Watson-Marlow or its distributor.

A certificate included at the rear of these operating instructions, or signed statement, must be attached to the outside of the shipping carton. This certificate is required even if the pump is unused. See 39 *Decontamination certificate*.

If the pump has been used, the fluids that have been in contact with the pump and the cleaning procedure must be specified along with a statement that the equipment has been decontaminated.

6 Peristaltic pumps - an overview

Peristaltic pumps are the simplest possible pump, with no valves, seals or glands to clog or corrode. The fluid contacts only the bore of a tube, eliminating the risk of the pump contaminating the fluid, or the fluid contaminating the pump. Peristaltic pumps can operate dry without risk.

How they work

A compressible tube is squeezed between a roller and a track on an arc of a circle, creating a seal at the point of contact. As the roller advances along the tube, the seal also advances. After the roller has passed, the tube returns to its original shape, creating a partial vacuum which is filled by fluid drawn from the inlet port.

Before the roller reaches the end of the track, a second roller compresses the tube at the start of the track, isolating a packet of fluid between the compression points. As the first roller leaves the track, the second continues to advance, expelling the packet of fluid through the pump's discharge port. At the same time, a new partial vacuum is created behind the second roller into which more fluid is drawn from the inlet port.

Backflow and siphoning do not occur, and the pump effectively seals the tube when it is inactive. No valves are needed.

The principle may be demonstrated by squeezing a soft tube between thumb and finger and sliding it along: fluid is expelled from one end of the tube while more is drawn in at the other.

Animal digestive tracts function in a similar way.

Suitable applications

Peristaltic pumping is ideal for most fluids, including viscous, shear-sensitive, corrosive and abrasive fluids, and those containing suspended solids. They are especially useful for pumping operations where hygiene is important.

Peristaltic pumps operate on the positive displacement principle. They are particularly suitable for metering, dosing and dispensing applications. Pumps are easy to install, simple to operate and inexpensive to maintain.

7 Safety notes

In the interests of safety, this pump and the tubing selected should only be used by competent, suitably trained personnel after they have read and understood this manual, and considered any hazard involved. If the pump is used in a manner not specified by Watson-Marlow Ltd, the protection provided by the pump may be impaired.

Any person who is involved in the installation or maintenance of this equipment should be fully competent to carry out the work. In the UK this person should also be familiar with the Health and Safety at Work Act 1974.



This symbol, used on the pump and in this manual, means: Caution, refer to accompanying documents.



This symbol, used on the pump and in this manual, means: Do not allow fingers to contact moving parts.



Fundamental work with regard to lifting, transportation, installation, starting-up, maintenance and repair should be performed by qualified personnel only. The unit must be isolated from mains power while work is being carried out. The motor must be secured against accidental start-up.



There is a user-replaceable type T2,5A H 250V fuse in the fuseholder in the centre of the switch-plate at the back of the pump. The 520N module must be removed to allow access to the switch-plate. See 22.1 *520N module fitting*. There is a fuse on the interface card which self-resets after five seconds. There are no user-serviceable fuses or parts inside this pump.

There are moving parts inside the pumphead. Before opening the tool-unlockable pumphead guard, ensure that the following safety directions are followed.

- Ensure that the pump is isolated from the mains power.
- Ensure that there is no pressure in the pipeline.
- If a tube failure has occurred, ensure that any fluid in the pumphead has been allowed to drain to a suitable vessel, container or drain.
- Ensure that protective clothing and eye protection are worn if hazardous fluids are pumped.
- Primary operator protection from rotating parts of the pump is provided by the pumphead safeguard. Note that safeguards differ, depending on the type of pumphead. See 28 *The 520R, 520R2 and 520RE pumpheads*.

This pump must be used only for its intended purpose.

The pump must be accessible at all times to facilitate operation and maintenance. Access points must not be obstructed or blocked. Do not fit any devices to the drive unit other than those tested and approved by Watson-Marlow. Doing so could lead to injury to persons or damage to property for which no liability can be accepted.

If hazardous fluids are to be pumped, safety procedures specific to the particular fluid and application must be put in place to protect against injury to persons.

The exterior surfaces of the pump may get hot during operation. Do not take hold of the pump while it is running. Let it cool after use before handling it. The drive unit must not be run without a pumphead fitted.



This product does not comply with the ATEX directive and must not be used in explosive atmospheres.

8 Pump specifications

Labels fixed to the rear of the pump contain manufacturer and contact details, product reference number, serial number and model details.

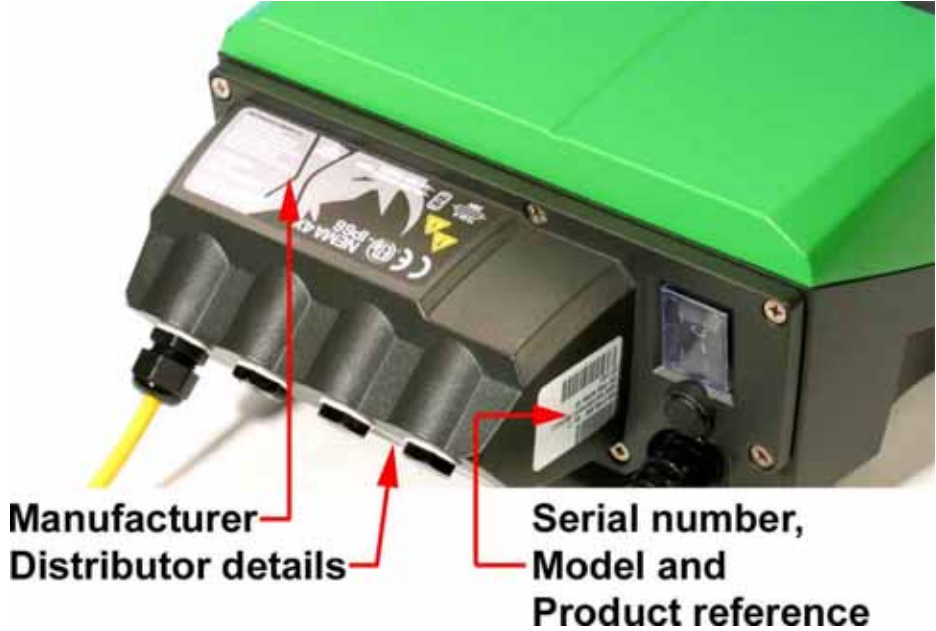

The same information is carried on the drive's backplate, accessible when the 520N module is removed.

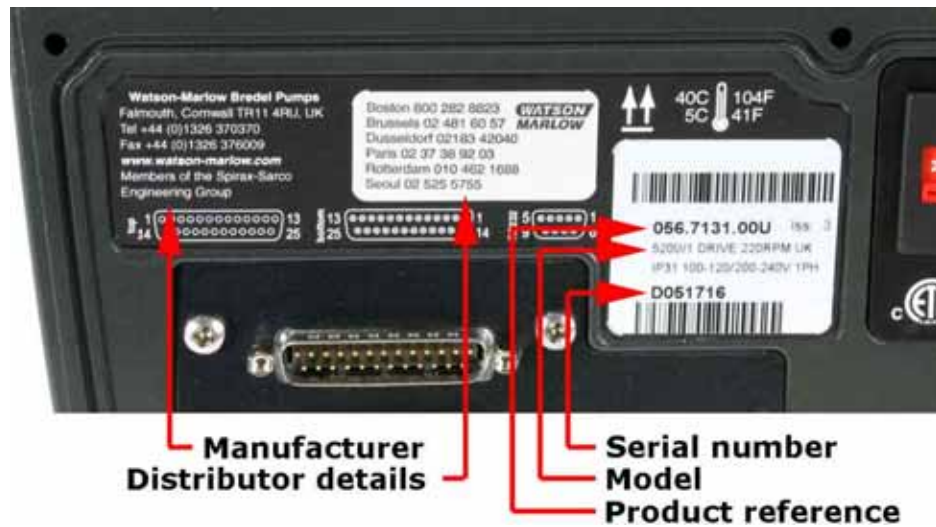

520DuS, NEMA 4X model

This pump can be controlled from the keypad or remotely. It features:

Manual control

Speed adjustment; run and stop; direction control; keypad scaling; "max" key for rapid priming.

Remote control

The pump can be digitally controlled with a contact closure or logic input signal to operate the pump.

Analogue control

The pump speed can be controlled through an analogue signal input in the ranges 0-10V or 4-20mA. Scaling can be controlled similarly using Analogue signal input 2.

Network control

RS485 network communication. Up to 32 pumps may be centrally controlled using standard Watson-Marlow commands.

Outputs

A 0-10V or 4-20mA output signal provides feedback of the pump speed. There are four relay status outputs which can be configured in software for a variety of pump parameters.

MemoDose

Allows precise repeat dosing. Stores in memory a pulse count from the motor. This count is repeated each time START is pressed to provide a single-shot dose.

Calibration

Full calibration with default figures for a range of pumpheads and tubes. Calibration dose facility.

IP (Ingress Protection) and NEMA definitions

IP		NEMA
1st Digit	2nd Digit	
3 Protected against ingress of solid objects with a diameter of more than 2.5mm. Tools, wires etc with a thickness of more than 2.5mm are prevented from approach	1 Protection against dripping water falling vertically. No harmful effect must be produced	2 Indoor use to provide a degree of protection against limited amounts of falling water and dirt
5 Protected against harmful dust deposits. Ingress of dust is not totally prevented but the dust must not enter in sufficient quantity to interfere with satisfactory operation of the equipment. Complete protection against contact	5 Protection against water projected from a nozzle against the equipment (enclosure) from any direction. There must be no harmful effect (water jet)	12 Indoor use to provide a degree of protection against dust, falling dirt and dripping, non-corrosive liquids
		13 Indoor use to provide a degree of protection against dust and spraying water, oil and non-corrosive coolants
6 Protection against ingress of dust (dust-tight). Complete protection against contact	6 Protection against heavy seas or powerful water jets. Water must not enter the equipment (enclosure) in harmful quantities (splashing over)	4X Indoor or outdoor* use to provide a degree of protection against splashing water, wind-blown dust and rain, hose-directed water; undamaged by the formation of ice on the enclosure. (Resist corrosion: 200-hour salt spray)

* 520N cased pumps are rated to NEMA 4X (indoor use) only.

Pump specifications

Control range (turndown ratio)	0.1-220rpm (2,200:1)
Supply voltage/frequency	100-120V/200-240V 50/60Hz 1ph
Maximum voltage fluctuation	±10% of nominal voltage. A well regulated electrical mains supply is required along with cable connections to the best practice of noise immunity
Installation category (overvoltage category)	II
Power consumption	135VA
Full load current	<0.6A at 230V; <1.25A at 115V
Eprom version	Accessible through pump software
Enclosure rating	NEMA 4X to NEMA 250 *
Pumphead options	520R, 501RL, 313, 314, 505L, 505BA, 505CA, 314MC, 318MC
Operating temperature range	5C to 40C, 41F to 104F
Storage temperature range	-40C to 70C, -40F to 158F
Maximum altitude	2,000m, 6,560ft
Humidity (non-condensing)	80% up to 31C, 88F, decreasing linearly to 50% at 40C, 104F
Pollution degree	2
Noise	<70dB(A) at 1m

* Protect from prolonged UV exposure.

Note: 520 drive models are c ETL us listed. Cert to std CAN/CSA C22.2 No 1010-92. Conforms to std UL 61010A-1 April 30, 2002.

Note: 520 drive models have been tested in accordance with BS EN 61000-6-2:2001 (EN 61000-4-4) Fast Transient and Burst Tests to Industrial limits - ie: Level 3 : 2kV.

Standards

EC harmonised standards	Safety of machinery—electrical equipment of machines: BS EN 60204-1
	Safety requirements for electrical equipment for measurement, control and laboratory use: BS EN 61010-1 incorporating A2 Category 2, Pollution degree 2
	Degrees of protection provided by enclosures (IP code): BS EN 60529 amendments 1 and 2
	Conducted emissions: BS EN 55011 A1 and A2 Class A, called by BS EN61000-6-4
	Radiated emissions: BS EN 55011 A1 and A2 Class A, called by BS EN61000-6-4
	Electrostatic discharge: BS EN 61000-4-2
	Radiated RF immunity: BS EN 61000-4-3 A1 and A2, called by BS EN 61000-6-2
	Fast transient burst: BS EN 61000-4-4 A1 and A2, Level 3 (2kV), called by BS EN 61000-6-2
	Surge immunity: BS EN 61000-4-5 A1 and A2, called by BS EN 61000-6-2
	Conducted RF immunity: BS EN 61000-4-6, called by BS EN 61000-6-2
	Voltage dips and interruptions: BS EN 61000-4-11, called by BS EN 61000-6-2
	Mains harmonics: BS EN 61000-3-2 A2
	Pumps and pump units for liquids—common safety requirements: BS EN 809
	Other standards
CAN/CSA-C22.2 No 61010-1	
Conducted emissions FCC 47CFR, Part 15.107	
Radiated emissions FCC 47CFR, Part 15	
NEMA 4X to NEMA 250 (indoor use) for IP66 products only	

8.1 Dimensions

520DuS IP66/NEMA 4X model



Unit weights

	Drive only	+ 520R, 520R2	+ 520REL, 520REM, 520REH	+ 505L
NEMA 4X	10.58kg 23lb 5oz	11.48kg 25lb 5oz	11.40kg 25lb 2oz	13.06kg 28lb 13oz

9 Good pump installation practice

9.1 General recommendations

A correctly engineered installation will promote long tube life. Site the pump on a flat, horizontal, rigid surface, free from excessive vibration, to ensure correct lubrication of the gearbox. Allow a free flow of air around the pump to ensure that heat can be dissipated. Ensure that the ambient temperature around the pump does not exceed 40C.

The **STOP** key on the keypad will always stop the pump. However, it is recommended that a suitable local emergency stop device is fitted into the mains supply to the pump.

Do not stack pumps more than three high. When pumps are stacked, ensure that the ambient temperature around all the pumps in the stack does not exceed 40C.

The pump may be set up so that the direction of rotor rotation is clockwise or counter-clockwise, whichever is convenient. Please note, however, that for the 520R and 501RL pumpheads tube life will be greater if the rotor rotates clockwise; and that performance against pressure will be maximised if the rotor rotates counter-clockwise. To achieve 4 bar and 7 bar pressures using a 520RE pump and the appropriate rotor and element, the pump **must** rotate counter-clockwise.

Peristaltic pumps are self-priming and self-sealing against backflow. No valves are required in inlet or discharge lines, except as described below. Valves in the process flow must be opened before the pump operates. Users are advised to fit a pressure relief device between the pump and any valve on the discharge side of the pump to protect against damage caused by accidental operation with the discharge valve closed. Users of 520RE pumps at pressures up to 4 bar and 7 bar are advised to fit a non-return valve between the pump and the discharge pipework to avoid the sudden release of pressurised fluid in the unlikely event of element failure.

9.2 Do's and do not's

Do not build a pump into a tight location without adequate airflow around the pump.

Do ensure that when the 520N SCADA module is fitted the seals are intact and properly located.

Do ensure that the holes for cable glands are properly sealed to maintain the NEMA 4X rating.

Do not strap the control and mains power cables together.

Do keep delivery and suction tubes as short and direct as possible - though ideally not shorter than 1m - and follow the straightest route. Use bends of large radius: at least four times the tubing diameter. Ensure that connecting pipework and fittings are suitably rated to handle the predicted pipeline pressure. Avoid pipe reducers and lengths of smaller bore tubing than the pumphead section, particularly in pipelines on the suction side. Any valves in the pipeline (not usually needed with a self-priming peristaltic pump) must not restrict the flow. Any valves in the flow line must be open when the pump is running.

Do use suction and delivery pipes equal to or larger than the bore of the tube in the pumphead. When pumping viscous fluids use pipe runs with a bore several times larger than the pump tube.

Do ensure that on longer tube runs at least 1m of smooth bore flexible tubing is connected to the inlet and discharge port of the pumphead to help to minimise impulse losses and pulsation in the pipeline. This is especially important with viscous fluids and when connecting to rigid pipework.

Do site the pump at or just below the level of the fluid to be pumped if possible. This will ensure flooded suction and maximum pumping efficiency.

Do keep the pumphead track and all moving parts clean and free from contamination and debris.

Do run at slow speed when pumping viscous fluids. When using the 520R pumphead, a 6.4mm or 4.8mm bore tube with a 2.4mm wall will give best results. Tube smaller than this will generate a high friction loss, so reducing the flow. Tube with a larger bore may not have sufficient strength to reconstitute fully. Flooded suction will enhance pumping performance in all cases, particularly for materials of a viscous nature.

Do recalibrate after changing pump tubes, fluid, or any connecting pipework. It is also recommended that the pump is recalibrated periodically to maintain accuracy.

NEMA 4X models may be hosed down, but should not be immersed. Protect from prolonged UV exposure.

When using Marprene or Bioprene continuous tubing, **do** re-tension the tube after the first 30 minutes of running.

Tube selection: The chemical compatibility lists published in Watson-Marlow publications are guides. If in doubt about the compatibility of a tube material and the duty fluid, request a Watson-Marlow tube sample card for immersion trials.

10 Connecting this product to a power supply



The voltage selector is mounted in the switchplate at the rear of the pump, protected from water by the 520N module. The module must be removed to allow access to the switchplate. See 22.1 *520N module fitting*. Set the voltage selector to 115V for 100 -120V 50/60Hz supplies or 230V for 200-240V 50/60Hz supplies. Always check the voltage selector switch before connecting the mains supply.

Make suitable connection to an earthed single-phase mains electricity supply.



The voltage selector switch is not visible while the 520N module is in place. Do not switch the pump on unless you have checked that it is set to suit your power supply by removing the module and inspecting the switch, and then refitting the module. See 22.1 *520N module fitting*.



We recommend using commercially available supply voltage surge suppression where there is excessive electrical noise.

Power cable: The pump is supplied fitted with a cable gland and approximately 2.8m of power cable. Recommended cable: H05RN-F3G0.75; SJTW 105C 3-18AWG; max OD 8mm (5/16in).

This drawing shows the cable connections from below with the interface card cover removed.

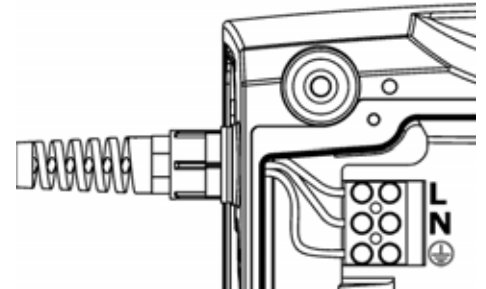

If the mains power cable is inappropriate for your installation, it can be changed. This operation can be carried out with the 520N module in place, or after it has been removed, as shown here for clarity.



- Ensure that the pump is isolated from the mains power.
- Remove the six screws from the interface card cover underneath the pump. Lift off the interface card cover. You may find it convenient to remove the cover completely; if so, remove the cover earth lead.
- Undo the terminal block connectors. Remove the restraining clip by sliding its jaws sideways in opposite directions.
- Loosen the cable gland using a 19mm wrench and remove the gland and the cable.
- Thread a replacement cable through the three parts of the gland, the pump case and the restraining clip. Connect the new cable to the block connectors, following the drawing above.
- Tighten the restraining clip and the gland to 2.5Nm. Check that the card cover earth link is secure. Replace the card cover, checking that the earth wire is not pinched beneath the cover lip. Take care that the sealing strip is properly seated to ensure a seal.



Input line fusing: type T2,5A H 250V 20mm time-delayed fuse, located in a fuseholder in the centre of the switchplate at the rear of the pump.

Power interruption: This pump has an auto-restart feature which, when active, will restore the pump to the operating state it was in when power was lost. See 18.12 *Auto-restart*.

Stop / start power cycles: Do not power up/power down for more than 100 starts per hour, whether manually or by means of the auto-restart facility. We recommend remote control where a high frequency of power cycles is required.

11 Start-up check list

Note: See also 29.2 *Tube loading*.

- Ensure that proper connections are achieved between the pump tube and suction and discharge piping.
- Ensure proper connection has been made to a suitable power supply.
- Ensure that the recommendations in the section 9 *Good pump installation practice* are followed.

12 Switching the pump on for the first time

Note: This manual uses **bold** type to highlight the active option in menu screens: “**English**” in the first screen represented here. The active option appears on the pump display in **inverse** text.

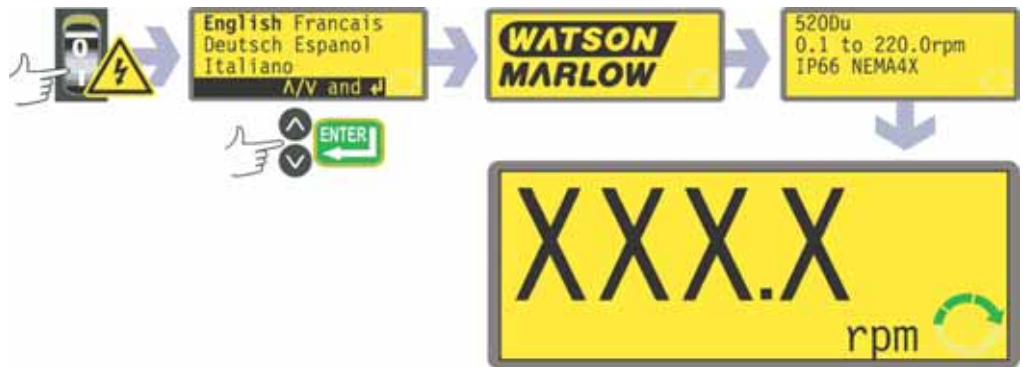

- Switch on the power supply at the rear of the pump. The pump runs a power-on test to confirm proper functioning of the memory and hardware. If a fault is found, an error message is displayed. See 25.1 *Error codes*.
- The pump displays a language menu. Use the **UP** and **DOWN** keys to select your language. Press the **ENTER** key to confirm your choice.
The information which follows assumes that your choice was English. When the language is chosen this menu will not appear again and all menus will appear in the language you chose. (Language can be reset as described later. See 18.16 *Language*.)
- The pump displays the Watson-Marlow start-up screen for four seconds, followed by the pump model identity screen for four seconds, and then the manual mode main screen.
- The rotation symbol on the display indicates clockwise rotation. The speed of rotation is the pump's maximum. Other initial start-up operational parameters are listed in the table below.

First-time start-up defaults			
Language	Not set	Analogue inputs	4-20mA
Speed	Maximum	User trim	None
Direction	Clockwise	Remote stop	Open=run
Pumphead	520R	Pump number	1
Tube size	9.6mm	Baud rate	9600
Calibration	from head and tube table	Stop bits	2
Backlight	On	Xon/Xoff	Off
Keypad lock	Off	Output 1	Run/Stop *
Auto-restart	Off	Output 2	Direction †
Scaling	Off	Output 3	Auto/Man ‡
Pump status	Stopped	Output 4	General alarm
Beeper	On	Run*	= High
Manual screen	rpm	Clockwise rotation †	= High
Security code	Not set	Auto ‡	= High

Note: The settings shown above for Run, Clockwise rotation and Auto are those in force on initial start-up for the functions available on Output 1, Output 2 and Output 3 respectively. For example, a high signal on Output 2 indicates clockwise rotation. These can be exchanged later according to user requirements.

The pump is now ready to operate according to the defaults listed above.

All operating parameters may be changed by means of key-presses. See 14 *Manual operation*.

13 Switching the pump on in subsequent power cycles (if not in auto-restart mode)

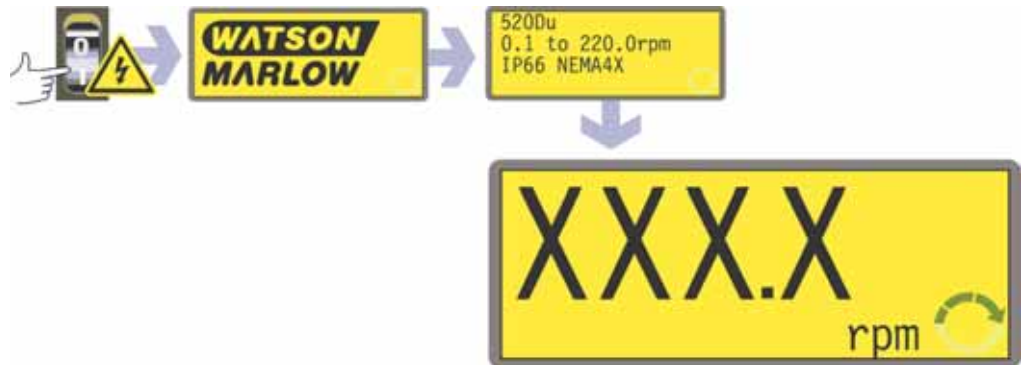

- Switch on the power supply at the rear of the pump. The pump runs a power-on test to confirm proper functioning of the memory and hardware. If a fault is found, an error message is displayed. See 25.1 *Error codes*.
- The pump displays the Watson-Marlow start-up screen for four seconds followed by the pump model identity screen for four seconds, and then the manual mode main screen.
 - **Note:** If ANY key is pressed during the display of any of the preliminary screens, the display jumps to the next screen. Quickly pressing any two keys or any key twice immediately after switch-on causes the display to jump to the manual mode main screen. Once in the manual mode main screen, keys assume their normal functions - see 14.1 *Keypad functions in manual mode* below. A subsequent press on **START** causes the pump to operate.
- Start-up defaults are those in place when the pump was switched off last. Check that the pump is set to operate as you require it.

The pump is now ready to operate.

All operating parameters may be changed by means of key-presses. See 14 *Manual operation*.

14 Manual operation

14.1 Keypad functions in manual mode

All settings and functions of the pump in manual mode are set and controlled by means of key-presses. Immediately after the start-up display sequence detailed above, the manual mode main screen will be displayed. The currently selected rotation direction is indicated on the display by a clockwise or counter-clockwise segmented arrow. If an exclamation mark (!) shows, it indicates that Auto-restart is on (see 18.12 *Auto-restart*). If a padlock icon (🔒) shows, it indicates that Keypad lock is on (see 14.2 *Keypad lock*).

Note: A number of the controls listed below are shortcuts to commands which are also available through the Main menu. See 15 *Main menu*.

A brief single press on each key triggers a beep sound (if enabled - see 18.18 *Beep*) and causes the pump to function as follows:



- **START:** starts the pump at the speed and in the direction shown on the display. The rotation symbol will become animated to confirm that the pump is operating. We recommend that the speed is reduced to a minimum (0.1 rpm) before starting the pump.



If the pump is running when **START** is pressed, it causes the information shown on the manual mode main screen to cycle from revolutions per minute, to flowrate in a choice of units (via a warning screen if flowrate has not been calibrated and if this is the first cycle since power-up) to rpm, flowrate and Run time. An example is shown here. (See 17 *Calibrate*. See 18.9 *Run time*.) This cycle operates in a similar way if **ENTER** is pressed when the pump is stopped. The default can be altered from within the Setup menu. See 18.3 *Display*.

- **MAX**: while pressed, **MAX** operates the pump at the maximum allowed speed and in the direction shown on the display. When released, the pump returns to its previous status.
Note: Priming can be achieved by pressing the **MAX** key until fluid flows through the pump and reaches the point of discharge, and then releasing the **MAX** key.

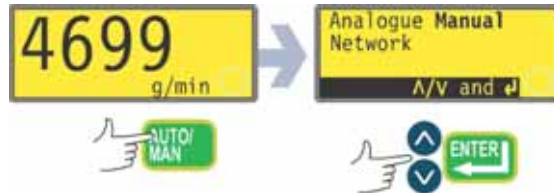

- **AUTO/MAN**: displays a screen offering three choices: manual control, analogue control or network (RS232) control. Use the **UP** and **DOWN** keys to make a choice. Press the **ENTER** key to confirm your decision. When started under analogue or network control, the pump runs at the speed set by any analogue or RS232 signal applied to the pump, and in the direction shown in the display.
- **STOP**: has no effect if the pump is not running. If the pump is running, pressing **STOP** stops the pump. The display will continue to show the previous speed and direction. The pump will return to this speed and direction when the **START** key is pressed again.
- **UP**: increases the speed shown on the display in minimum steps of 0.1 rpm (unless the speed displayed is already the maximum allowed speed). If the pump is then started by pressing the **START** key, it will operate at the new speed. If the pump is running when **UP** is pressed, the change takes effect immediately.
Note: After a speed change (if the pump has been calibrated), a screen showing the new rpm figure **and** the new flowrate is displayed for four seconds before returning the user to the previously set manual mode main screen: rpm **or** flowrate.
- **DOWN**: decreases the speed shown on the display in minimum steps of 0.1 rpm. If the pump is then started by pressing the **START** key, it operates at the new speed. The minimum speed possible is 0.1 rpm. If the pump is running when **DOWN** is pressed, the change takes effect immediately.
Note: After a speed change (if the pump has been calibrated), a screen showing the new rpm figure **and** the new flowrate is displayed for four seconds before returning the user to the previously set manual mode main screen: rpm **or** flowrate.
Note: You can reduce the pump speed from 0.1 rpm to 0 rpm by a further press on the **DOWN** key. The pump is still in the running state and the rotation symbol will continue to move. Press the **UP** key to return the pump to the minimum speed.

- **DIRECTION**: toggles the direction of rotation shown on the display. If the pump is then started by pressing the **START** key, it rotates in the new direction. If the pump is running when **DIRECTION** is pressed, the change takes effect immediately.
- **ENTER**: cycles the information shown on the manual mode main screen from revolutions per minute, to flowrate in a choice of units (via a warning screen if flowrate has not been calibrated and if this is the first cycle since power-up) to rpm, flowrate and Run time. (See **START**, above. See 17 *Calibrate*. See 18.9 *Run time*.) This cycle operates when the pump is stopped and when it is running. The default can be altered from within the Setup menu. See 18.3 *Display*.
- **MENU**: causes the main menu to be displayed, from which all aspects of pump setup can be controlled. See 15 *Main menu*.

Keypress combinations cause the pump to function as follows:

- **UP** and **DIRECTION** on power-up: toggles the keypad beep on and off.
- **START** on power-up: switches on the Auto-restart facility. See 18.12 *Auto-restart*.
- **STOP** on power-up: switches off the Auto-restart facility. See 18.12 *Auto-restart*.
- **STOP** and **DIRECTION** on power-up: allows the user to press **UP** and **DOWN** keys to toggle the sense of remote run / stop control between open=stop and open=run.
- **STOP** and **UP** while the pump is stopped: turns the display backlight on.
- **STOP** and **DOWN** while the pump is stopped: turns the display backlight off.
- **MAX** and **UP**: sets the pump to maximum allowed speed.
- **MAX** and **DOWN**: sets the pump to minimum speed.
- **DIRECTION** and **DOWN**: interrupts the display to show the pump's ROM version for four seconds.
- **START** pressed and held for two seconds: toggles the keypad lock on and off. Only the **START** and **STOP** keys are active when keypad lock is on. The padlock icon is displayed.
- **STOP** pressed and held for two seconds: toggles the keypad lock on and off. Only the **START** and **STOP** keys are active when keypad lock is on. The padlock icon is displayed.
- **STOP STOP** within half a second: shortcut entry to MemoDose; when in MemoDose, shortcut return to manual mode main screen. See 20 *MemoDose*.

Note: The maximum allowed speed of the drive defaults to 220 rpm. It is possible to set this limit at any speed up to this value. See 18.13 *Set maximum speed*.

14.2 Keypad lock

The keypad can be locked to prevent changes to pump speed or other settings, and make it possible only to start or stop the pump. The padlock symbol shows on the display.

- While the pump is running, hold down the **START** key for two seconds. The padlock symbol shows and only the **START** and **STOP** keys function.
- The keypad may also be locked while the pump is stopped. Hold down the **STOP** key for two seconds. The padlock symbol shows and only the **START** and **STOP** keys function.
- To unlock the keypad while the pump is running hold down the **START** key for two seconds. The padlock symbol is removed. If the pump is stopped hold down the **STOP** key until the padlock symbol is removed.

14.3 Keypad beep

The pump keypad can operate silently or indicate a positive key-press with a beep sound.

- To toggle the sound on and off, stop the pump. Turn off the mains power switch at the rear of the pump.
- Depress the **UP** and **DIRECTION** keys while switching on the mains power switch at the rear of the pump.

14.4 Manual operation and remote digital inputs and outputs

The remote run / stop, direction and leak-detected inputs are operational.

The remote status outputs are all fully functional.

The **STOP** key acts as an overriding emergency stop. The run / stop input will not start the pump in manual mode, but once the **START** key has been pressed, the remote run / stop input will stop and start the pump according to its operational state.

In its default state, a signal of 80VAC to 130VAC applied across the terminals of the Run/stop input connector (J4) will stop the pump. When no signal is applied, the pump will run (when **START** is pressed). If the operation of Run/stop is inverted (through the Setup menu), the pump will run when a signal is applied (and **START** is pressed) and stop when no signal is applied.

If **STOP** is pressed the remote run / stop switch will have no effect.

You cannot invert the polarity of the remote direction signal.

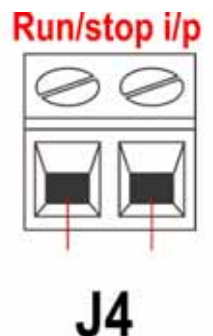

15 Main menu

15.1 Keypad functions in menu screens

In addition to their functions in other operations, the following keys have specific actions in menu screens:

- **STOP**: In general, **STOP** functions as a “go back” key, taking the user up one menu level without making a change.
- **UP**: The **UP** key is used in menu item selection: it moves a highlight up the menu. When a numerical entry screen is displayed, pressing **UP** increases the number displayed.
- **DOWN**: The **DOWN** key is used in menu item selection: it moves a highlight down a menu. When a numerical entry screen is displayed, pressing **DOWN** decreases the number displayed.
- **ENTER**: The **ENTER** key functions in a similar way to the “enter” key of a personal computer: it confirms key-presses made immediately before. In menu item selection, it triggers the action or display selected from a menu using the **UP** and **DOWN** keys.



Note: Confirmation screens are displayed for 4 seconds. While they are displayed, a single press on any key removes them.

15.2 Main menu entry

The **MENU** key displays the main menu. It operates at any point in the pump's activity except where error screens are displayed, or screens where **UP** and **DOWN** keys are used to enter values.



The main menu offers five options: **Calibrate**, **Setup**, **Pin out details**, **MemoDose** and **Exit**. Use the **UP** and **DOWN** keys to make a choice. Press the **ENTER** key to confirm your decision.

Calibrate

Calibrate allows the user to calibrate the pump with default figures for a range of pumpheads and tubes, as well as to refine the flowrate figures with a calibration dose facility.

Setup

Setup allows the user to set the pump's operating parameters under 20 headings: **Trim**, **Analogue**, **Display**, **Pump number**, **Baud**, **Stop bits**, **Xon/Xoff**, **Flow units**, **Run time**, **Outputs**, **Remote stop**, **Auto-restart**, **Set max speed**, **Backlight**, **ROM**, **Language**, **Defaults**, **Beep**, **Security** and **Exit**.

Pin out details

Pin out information is not relevant to the 520DuS IP66/NEMA 4X SCADA pump. Selecting **Pin out details** causes the pump to display a warning screen and redisplay the main menu.

MemoDose

The **MemoDose** facility is used to remember the number of revolutions needed to dispense a set volume of fluid, and cause the pump to dispense that volume repeatedly.

Exit

If **Exit** is selected, the pump returns to its last manual state with the pump stopped.

16 PIN-secure process protection

The 520DuS features PIN-secure process protection. This allows the pump to be configured to suit the application, and for the setup to be protected by two levels of PIN code. See 18.19 *Security code*.

Menu option or keypress	With Main code set	With User code set	Code set and keypad locked
Menu	Available	Available	Not available
Calibrate	Available	Available	Not available
Accept	Available	Available	Not available
Change	Main PIN needed	Main PIN or User PIN needed	Not available
Setup	Main PIN needed	Main PIN needed; User PIN invalid	Not available
MemoDose	Available	Available	Available*
Pin out details	Available	Available	Not available
Max	Available	Available	Not available
Dir	Main PIN needed	Main PIN or User PIN needed	Not available
Auto / Man	Available	Available	Not available
Up	Available	Available	Not available
Down	Available	Available	Not available
Max and Up	Available	Available	Not available
Max and Down	Available	Available	Not available
Start	Available	Available	Available
Stop	Available	Available	Available
Enter	Available	Available	Not available
Keypad lock	Main PIN needed	Main PIN or User PIN needed	Main PIN or User PIN needed
Auto-restart	Available	Available	Available

* When the keypad is locked, MemoDose is available via its access shortcut: press **STOP** twice; it is not available through the menu structure.

The main code allows changes to **Calibrate**, **Setup**, **Direction** and **Keypad lock**.

The secondary (User) code permits **Calibrate**, **Direction** change and **Keypad lock** but bars **Setup** change.

If either code is used in conjunction with Keypad lock, all keys are disabled except **STOP** and **START**.

To activate and set a security code, see 18.19 *Security code*.

If the main code is lost or forgotten: The Setup main security code can be bypassed by entering a special key sequence; all codes can then be cancelled and reset. Contact Watson-Marlow or your distributor for details.

17 Calibrate

The pump can display flowrate in a choice of units as well as speed in revolutions per minute. It must first be calibrated.

Pump calibration can be limited to users who correctly enter a three-digit security code. If a security code has been set, selecting **Change** from the calibration details screen and confirming with the **ENTER** key causes the pump to display the Security code entry sequence. See 16 *PIN-secure process protection*. If no security code has been set, the pump displays the first screen of the calibration sequence.

To dispense the correct amount of fluid the pump must know which pumphead is fitted and the tube size in the pumphead. The pump is pre-programmed with default flow rate figures for a range of pumpheads and tubes. You may also measure the flow from the pump and enter this value for the most accurate calibration.

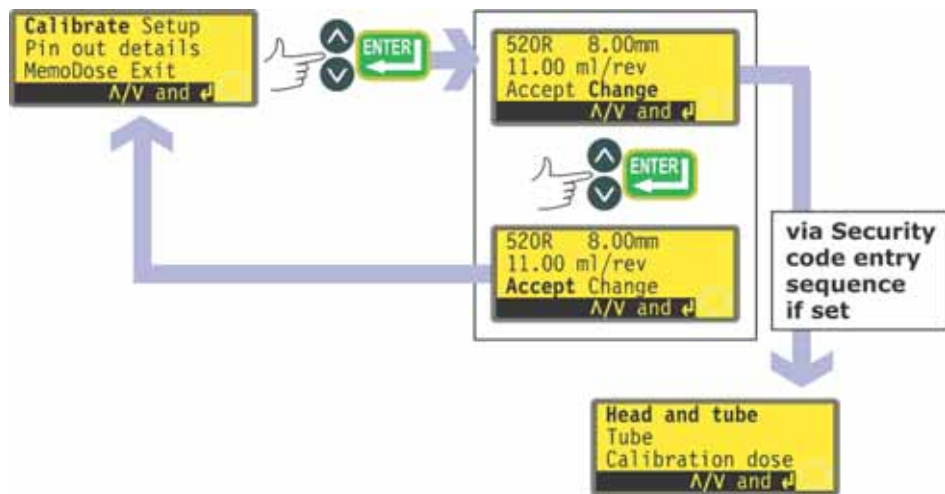

- Use the **UP** and **DOWN** keys to highlight **Calibrate** in the main menu. Press **ENTER** to confirm.
- The pump displays its current settings: pumphead, tube size and flowrate; the default for each standard pumphead is the largest tube the pumphead can take. Example information is shown here.
- Use the **UP** and **DOWN** keys to highlight **Accept** or **Change**. Press **ENTER** to confirm.
- If **Accept** is selected, the default or previously set flowrate data for that pumphead and tube size are used in flowrate calculations. The pump redisplay the main menu.
- If **Change** is selected with a security code in place, the pump starts its security code entry sequence. See 16 *PIN-secure process protection*. When the correct code is entered, the pump offers three options: **Head and tube**; **Tube**; and **Calibration dose**. If **Change** is selected with no security code in place, the three options are displayed immediately.
- Use the **UP** and **DOWN** keys to make a selection. Press **ENTER** to confirm.

Head and tube

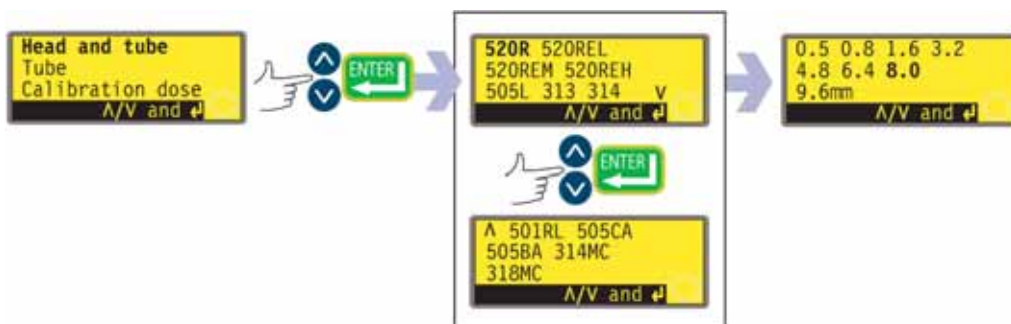

- If **Head and tube** is selected, the pump displays a list of standard pumpheads that can be fitted to the pump. It occupies two screens. Use the **UP** and **DOWN** keys to move the highlight down the list. When the last item on the first screen is highlighted, a further press on the **DOWN** key causes the pump to display the second screen with its first item highlighted.
- Use the **UP** and **DOWN** keys to make a selection. Press **ENTER** to confirm. An example is shown here.
- The pump displays tube sizes, as below.

Tube



- If **Tube** is selected or a pumphead choice has just been made, the pump displays a list of standard tube sizes that can be used in the pumphead previously identified.
- Use the **UP** and **DOWN** keys to make a selection. Press **ENTER** to confirm.

Calibration dose

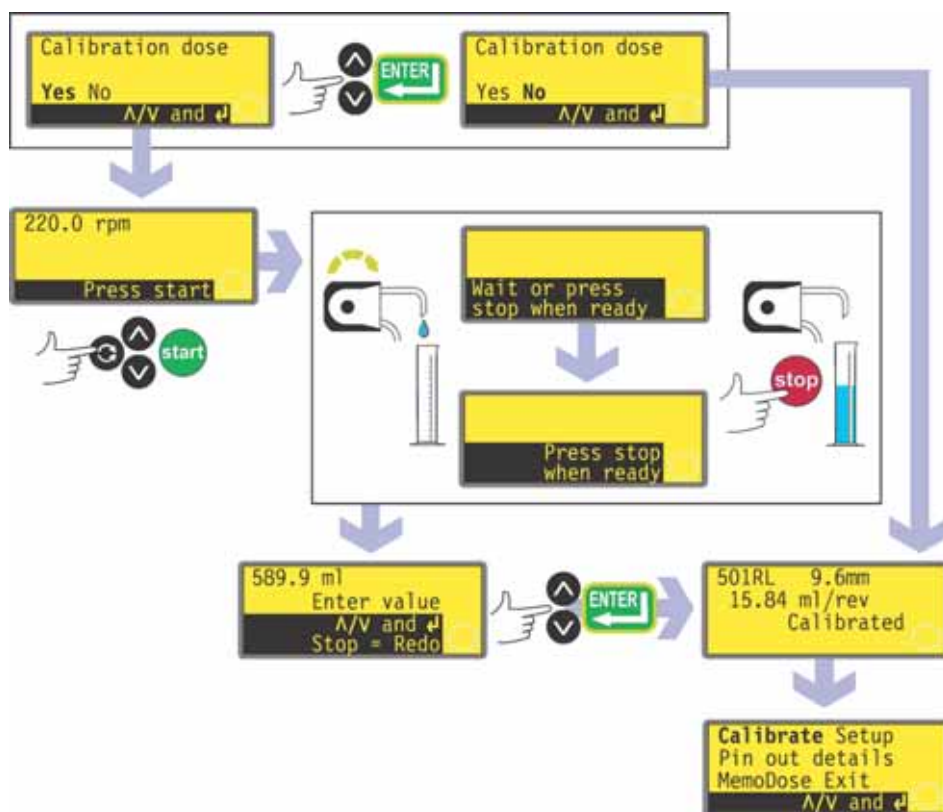

- The pump offers to run a calibration dose. Use the **UP** and **DOWN** keys to choose **Yes** or **No**. Press **ENTER** to confirm. Examples are shown here.
- If **No** is selected after a tube selection has been made (see *Tube* above), the pump briefly displays a confirmation screen showing current head, tube and flow settings, and redisplay the main menu.
- If **Calibration dose** is selected or if **Yes** is selected after a tube selection has been made (see *Tube* above), the pump displays the speed and direction at which it was last running in manual mode or to which it has just been set and invites the user to press **START**.
- **Note:** it is possible at this point to change the direction of rotation using the **DIRECTION** key, and the change the speed of rotation using the **UP** and **DOWN** keys, up to the pump's maximum speed or any (lower) maximum available speed which has previously been set. See 18.13 *Set maximum speed*.
- Put a measuring container at the pump outlet. Press **START**. The pump runs for 4 minutes, displaying an information screen for 15 seconds and a further information screen for the rest of the 4 minutes. You may stop the calibration dose at any time with the **STOP** key - but allow the pump to run as long as possible to obtain the most accurate calibration. A minimum of 15 seconds is recommended.

- Measure the quantity of fluid dispensed. The pump displays its calculated dose, based on previous calibration data. Use the **UP** and **DOWN** keys to adjust this reading to match the measured volume. Press **ENTER**. The pump displays the new head, tube and flow settings, and redisplayes the main menu. Example figures are shown here.



Note: If the pump has been set to display flow rate in units of mass (see 18.8 *Flow units*), as in this example, the pump displays a screen allowing you to confirm the specific gravity of the duty fluid immediately before the final press on **ENTER**.

Note: Always recalibrate after changing pump tubes, fluid, or any connecting pipework. It is also recommended that the pump is recalibrated periodically to maintain accuracy.

Note: If the pump power is cycled while flow rate is displayed, calibration is lost and a warning is displayed.

18 Setup

Entry to the Setup menu can be limited to users who correctly enter a three-digit security code. If a security code has been set, selecting **Setup** and confirming with the **ENTER** key causes the pump to display the Security code entry sequence. See 16 *PIN-secure process protection*. If no security code has been set, the pump displays the first of six screens containing the Setup menu.

The Setup menu

The Setup menu occupies six screens. The first two are shown here.

To move from one screen to subsequent screens, repeatedly press **DOWN**. Each item is highlighted in turn until the last item on the screen is highlighted.

A further press on the **DOWN** key displays the next screen of the menu, with the first item highlighted.

Follow the reverse procedure using the **UP** key to move to an item on a previous screen of the menu.

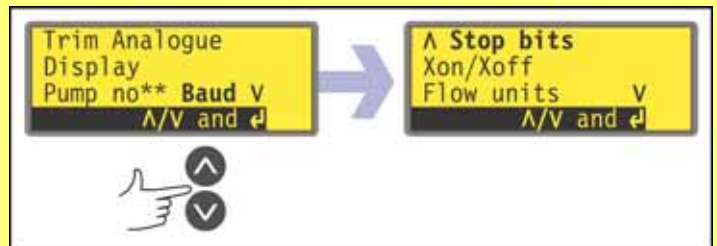

Make a selection using the **UP** or **DOWN** keys and press **ENTER** to confirm your choice.

18.1 Trim

When the pump is under remote control, it tracks an analogue signal from the user's remote control system to the **i/p** terminal of the Analogue 1 and Analogue 2 connectors at the rear of the pump within the ranges 4-20mA or 0-10V. The **Trim** setup sequence allows the user to customise the process-signal-to-pump-speed calibration. The sequence may be entered directly from the Setup menu or from the Analogue setup menu.

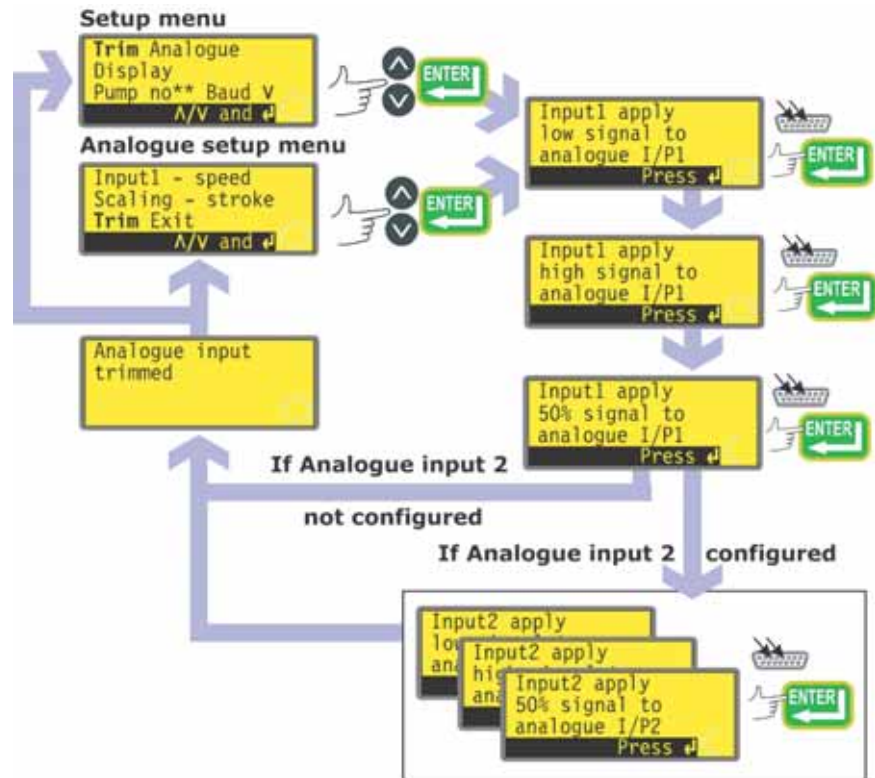

- Select **Trim** from the Setup menu or the Analogue setup menu using the **UP** or **DOWN** keys and press **ENTER** to confirm your choice.
- Apply the low process analogue signal to the **i/p** terminal of the Analogue 1 connector as instructed in the display. See 18.2 *Analogue*. While the signal is being applied, press **ENTER** to record the signal as a calibration point.
- Apply the maximum process control signal. While the signal is being applied, press **ENTER** to record the signal as a calibration point.
- Apply 50% of the maximum process control signal. While the signal is being applied, press **ENTER** to record the signal as a calibration point.
- If a mistake is made, press **STOP** at any point in the sequence, and the pump displays the previous screen.

- The final press on **ENTER** ends the Analogue 1 trimming sequence.
 - If Analogue 2 has been configured, the pump displays a similar sequence of screens for that input. Apply the low, high and mid-range signal to the **i/p** terminal of the Analogue 2 connector as instructed in the display, pressing **ENTER** each time to record the signals as calibration points.
 - If a mistake is made, press **STOP** at any point in the sequence, and the pump displays the previous screen.
 - The final press on **ENTER** ends the Analogue 2 trimming sequence.
- When trimming is complete the pump displays a confirmation screen and redisplay the screen from which it entered the trim sequence: the Setup menu or the Analogue setup menu.

The pump calculates linear responses from low to mid and from mid to high, and records the results as new analogue input calibration graphs.

If any of the three signals applied to each input match, a warning screen is displayed before the confirmation screen appears, and the trim is ignored.

Note: By applying the maximum process control signal when the minimum is requested and vice versa, inverted responses can be set up.

Note: Resetting factory defaults clears the trim calibration values.

18.2 Analogue

When the pump is under remote control, it tracks an analogue signal from the user's remote control system to the **i/p** terminal of the Analogue 1 connector at the rear of the pump within the ranges 4-20mA or 0-10V. The **Analogue** option in the Setup menu allows the user to configure the pump to operate with his remote control system.



- Select **Analogue** from the Setup menu using the **UP** or **DOWN** keys and press **ENTER** to confirm your choice.
- Four options are displayed: **Input 1 - speed**, **Scaling - stroke**, **Trim** and **Exit**.

Input 1 - speed allows the user to tell the pump which signal type he will apply to Analogue 1, or to choose the program option. If he selects **Program** from the subsequent menu, the user can choose his input type and tell the pump the speeds at which to operate on receiving a low or high process control signal. See *Input - speed*.

Scaling - stroke allows the user to disable scaling control, or if he wishes to enable scaling, to tell the pump which signal type he will apply to Analogue 2, or to choose the program option. If he selects Program from the subsequent menu, the user can choose his input type and tell the pump the speed proportion at which to operate on receiving a low or high process control signal. See 22.3 *Speed: analogue input 1*.

Trim displays the Trim menu, described above. See 18.1 *Trim*.

Exit returns the user to the first section of the Setup menu. See 18 *Setup*.

Input 1 - speed

- Select **Input 1 - speed** using the **UP** or **DOWN** keys and press **ENTER** to confirm your choice.
- The pump offers two further choices: **4-20mA** and **0-10V**. Use the **UP** or **DOWN** keys to make a selection and press **ENTER** to confirm your decision.



- The pump configures the hardware and factory-set response data and briefly displays a confirmation screen. The user is returned to the Analogue setup display. Example figures are shown here.
- Alternatively the user can select **Program** to configure the pump to respond in a user-programmed way to any process signal range within the limits described above.

Program

- Select **Program** using the **UP** or **DOWN** keys and press **ENTER** to confirm.
- The pump offers two choices: **mA** and **V**. Use the **UP** or **DOWN** keys to make a selection and press **ENTER** to confirm your decision.

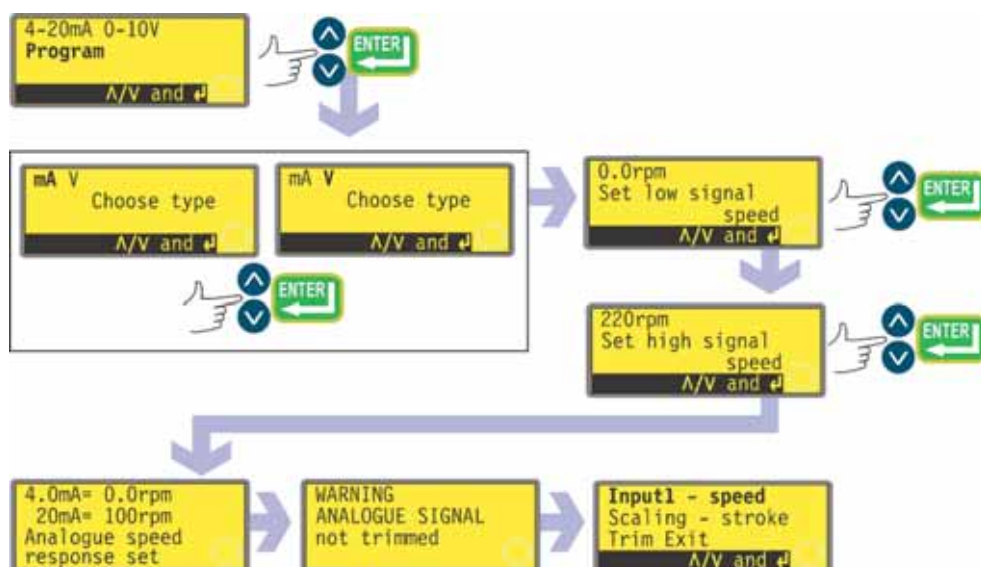

- The pump displays a screen allowing you to set the speed for low signal input. Use the **UP** and **DOWN** keys to scroll the display to your chosen speed and press **ENTER** to confirm the figure.
- The pump displays a screen allowing you to set the speed for high signal input. Use the **UP** and **DOWN** keys to scroll the display to your chosen speed and press **ENTER** to confirm the figure.
- If a mistake is made, the user may press **STOP** at any point in the sequence (before pressing **ENTER** on the high signal speed screen), and the pump will display the previous screen.
- The final press on **ENTER** causes the pump to configure the hardware and programmed response data. It briefly displays a confirmation screen and a warning that the analogue signal is not trimmed, and returns the user to the Analogue setup menu. Example values are shown here.

Scaling - stroke

- Select **Scaling - stroke** using the **UP** or **DOWN** keys and press **ENTER** to confirm your choice.
- The pump offers five further choices: **Off**, **Keypad**, **4-20mA**, **0-10V** and **Program**. Use the **UP** or **DOWN** keys to make a selection and press **ENTER** to confirm your decision.
- If **Off** is selected, scaling control is disabled and the pump displays the Analogue setup menu.
- The other options allow a choice of inputs to control scaling.
 - If **Keypad** is selected, scaling will be controlled by keypad entry of the scaling factor while the pump is running in Auto analogue mode.
 - If **4-20mA** or **0-10V** is selected, the pump configures the hardware and calibration data appropriately. A confirmation screen is displayed briefly and the user is returned to the Analogue setup screen.
 - If **Program** is selected, the pump offers two choices: **mA** and **V**. Use the **UP** or **DOWN** keys to make a selection and press **ENTER** to confirm your decision.
 - The pump displays a screen inviting the user to enter the required speed proportion for low signal input as a value from 0.0 to 1.0. Enter your value using the **UP** or **DOWN** keys and confirm by pressing **ENTER**.
 - A similar screen allows the user to enter the required speed proportion for high signal input as a value from 0.0 to 1.0. Enter the value in the same way.
 - If **STOP** is pressed at any point in the program setup (before pressing **ENTER** on the high signal speed proportion screen), the pump will display the previous screen.
 - When high and low values have been entered and confirmed, the pump configures the hardware and basic calibration data. A confirmation screen is displayed briefly, followed by a warning that the analogue signal has not been trimmed. The user is returned to the Analogue setup screen.

See 22.4 *Scaling: analogue input 2*.

Trim

Trim displays the Trim menu, described above. See 18.1 *Trim*.

It is recommended that a trim calibration is always performed to align the pump's response to the actual process analogue signal.

Exit

Exit returns the user to the first section of the Setup menu, described above. See 18 *Setup*.

18.3 Display

The pump can display three default screens in manual mode: revolutions per minute, flowrate in a choice of units, or both.

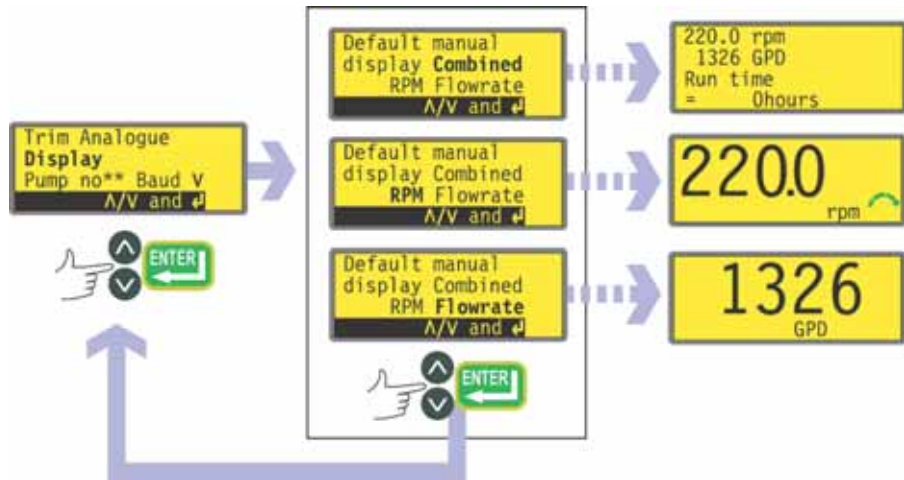

- In the first screen of the Setup menu select **Display** using the **UP** and **DOWN** keys. Press **ENTER** to confirm your choice.
- The pump displays a screen allowing you to choose the format of the manual mode main screen. Use the **UP** and **DOWN** keys to choose and press **ENTER** to confirm your decision.
- If you choose **Flowrate** and you have not calibrated the pump since switching it on, a warning screen is displayed for 4 seconds. The warning does not appear if the display screen formats are cycled again, unless the pump has been switched off in the mean time.
- The pump redisplay the first screen of the Setup menu.
- When the pump next runs, the manual mode main screen will display pump activity in rpm, flowrate (in the units you chose - see 18.8 *Flow units*) or both, according to your choice, plus a run time figure. Examples are shown here.

Alternatively ...

- In the manual mode main screen, repeatedly press **ENTER** to cycle the display between rpm, flowrate (in the units you chose - see 18.8 *Flow units*) or combined, according to your choice. This cycle operates if the pump is running and if it is stopped. While the pump is running, you can cycle the display in the same way by repeatedly pressing **START**. In both cases, if you have not calibrated the pump since switching it on, a warning screen is displayed for 4 seconds before the flowrate screen appears. The warning does not appear if the display screen formats are cycled again, unless the pump has been switched off in the mean time.
- The pump redisplay the first screen of the Setup menu.

18.4 Pump number

The 520DuS pump can be individually controlled under RS485 as one of up to 32 pumps. First it must be given its identity number.

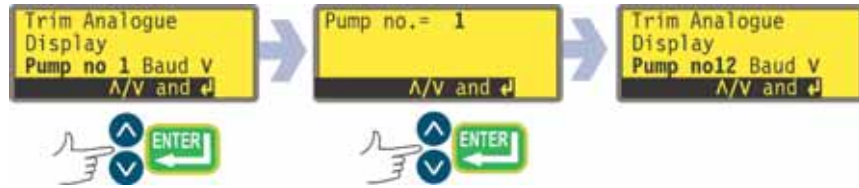

- In the first screen of the Setup menu select **Pump no 1** using the **UP** and **DOWN** keys. Press **ENTER** to confirm your choice.
- The pump displays a screen allowing you to change the pump's identity number. Use the **UP** and **DOWN** keys to change the number in the display to an integer from 1 to 32 and press **ENTER** to confirm your decision. An example is shown here.
- The pump displays the first screen of the Setup menu including the new identity number.

18.5 Baud

The 520DuS pump can be set to communicate with control devices at a choice of baud rates.



- In the first screen of the Setup menu select **Baud** using the **UP** and **DOWN** keys. Press **ENTER** to confirm your choice.
- The pump displays a screen allowing you to change the pump's baud rate. Use the **UP** and **DOWN** keys to select 1200, 2400, 4800, 9600 or 19k2 and press **ENTER** to confirm your decision.
- The pump displays the first screen of the Setup menu.

18.6 Stop bits

The 520DuS pump can be set to communicate with control devices at a choice of stop bits settings.



- In the second screen of the Setup menu select **Stop bits** using the **UP** and **DOWN** keys. Press **ENTER** to confirm your choice.
- The pump displays a screen allowing you to change the pump's stop bits setting. Use the **UP** and **DOWN** keys to select 2, 1, or 0 and press **ENTER** to confirm your decision.
- The pump displays the second screen of the Setup menu.

18.7 Xon/Xoff

The 520DuS pump can be set to communicate with control devices using Xon/Xoff flow control.

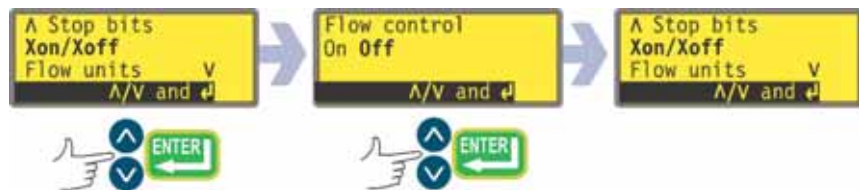

- In the second screen of the Setup menu select **Xon/Xoff** using the **UP** and **DOWN** keys. Press **ENTER** to confirm your choice.
- The pump displays a screen allowing you to set flow control on or off. Use the **UP** and **DOWN** keys to choose and press **ENTER** to confirm your decision.
- The pump displays the second screen of the Setup menu.

18.8 Flow units

The 520DuS pump can display its flow rate in metric (SI) or US (imperial) units of volume or mass.

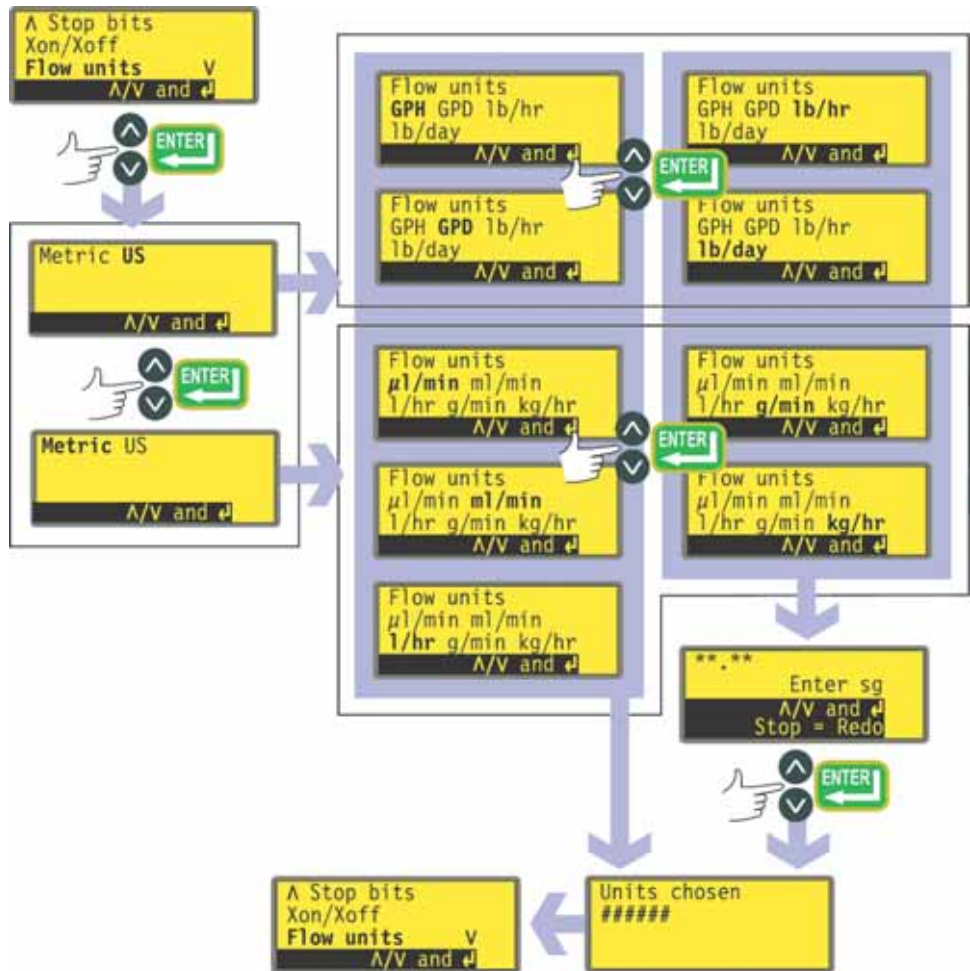

- In the second screen of the Setup menu select **Flow units** using the **UP** and **DOWN** keys. Press **ENTER** to confirm your choice.
- The pump displays a screen offering Metric or US. Use the **UP** and **DOWN** keys to choose and press **ENTER** to confirm your decision.
- If you chose Metric, the pump offers a choice of units: µl/min, ml/min, l/hr, g/min or kg/hr. Use the **UP** and **DOWN** keys to choose and press **ENTER** to confirm your decision.
- If you chose US, the pump offers a choice of units: US Gallons/hr, US Gallons/day, lb/hr or lb/day. Use the **UP** and **DOWN** keys to choose and press **ENTER** to confirm your decision.

- If you chose a volumetric flow rate from either screen, a confirmation screen appears briefly and the pump displays the second screen of the Setup menu.
- If you chose a mass flow rate from either screen, the pump asks for the specific gravity of the fluid to be pumped. Use the **UP** and **DOWN** keys to enter a value between 0.01 and 15.00. Press **ENTER** to confirm your decision. Press **STOP** if you decide to make a different choice of units.
- A confirmation screen appears briefly and the pump displays the second screen of the Setup menu.

18.9 Run time

The 520DuS pump cumulatively records how many complete hours its motor runs. The figure can be displayed or reset to zero.

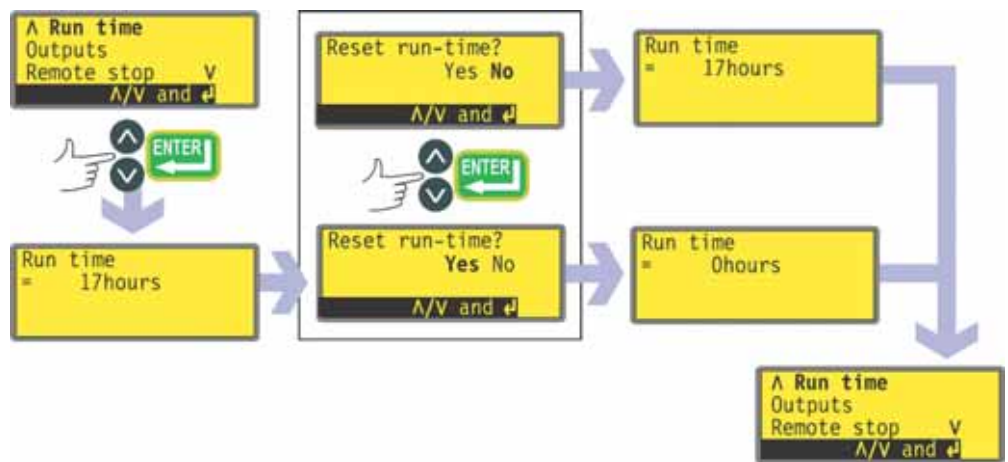

- In the third screen of the Setup menu select **Run time** using the **UP** and **DOWN** keys. Press **ENTER** to confirm your choice.
- The pump briefly displays the total hours its motor has operated since the last time the counter was reset to zero hours, followed by an opportunity to reset the counter to zero hours. An example is shown here. Use the **UP** and **DOWN** keys to choose **Yes** or **No** and press **ENTER** to confirm your decision.
- The total hours screen is briefly displayed with its total reset to zero hours, or unchanged, as appropriate. The pump displays the third screen of the Setup menu.

Note: Run time is displayed on the Combined display. See 18.3 *Display*. Run time does not zero when factory default is selected.

18.10 Outputs

The 520DuS pump offers four relay status outputs. See 12 *Switching the pump on for the first time* for initial startup defaults. Each of five parameters can be configured to any output, or more than one output.

The parameters are:

Run / stop

Provides a status output to indicate whether the pumphead is in a running or stopped condition. When running at 0rpm, the run / stop output indicates running.

Direction

Provides a status output to indicate which direction the pump is set to run in.

Auto / man

Provides a status output to indicate whether the pump is in analogue control mode or manual control mode.

General alarm

Provides an alarm output when any system error condition occurs except: leak detected; analogue signal out of range; analogue over-signal; analogue no signal.

Leak detected

When used with a leak detector, this output provides an alarm when the pump has been automatically switched off following tube failure.

Outputs 1-4 are available as single-pole change-over relay contacts: Relay 1, 2, 3 and 4. Connect to the normally open or normally closed contacts of the relay as required and configure the pump's software accordingly. See below in this section.

Note: The maximum rating on the relay contacts of this pump is 130VAC; max current 2A.

Important: never apply mains power to the relays; all voltage supplies must be transformer-isolated.

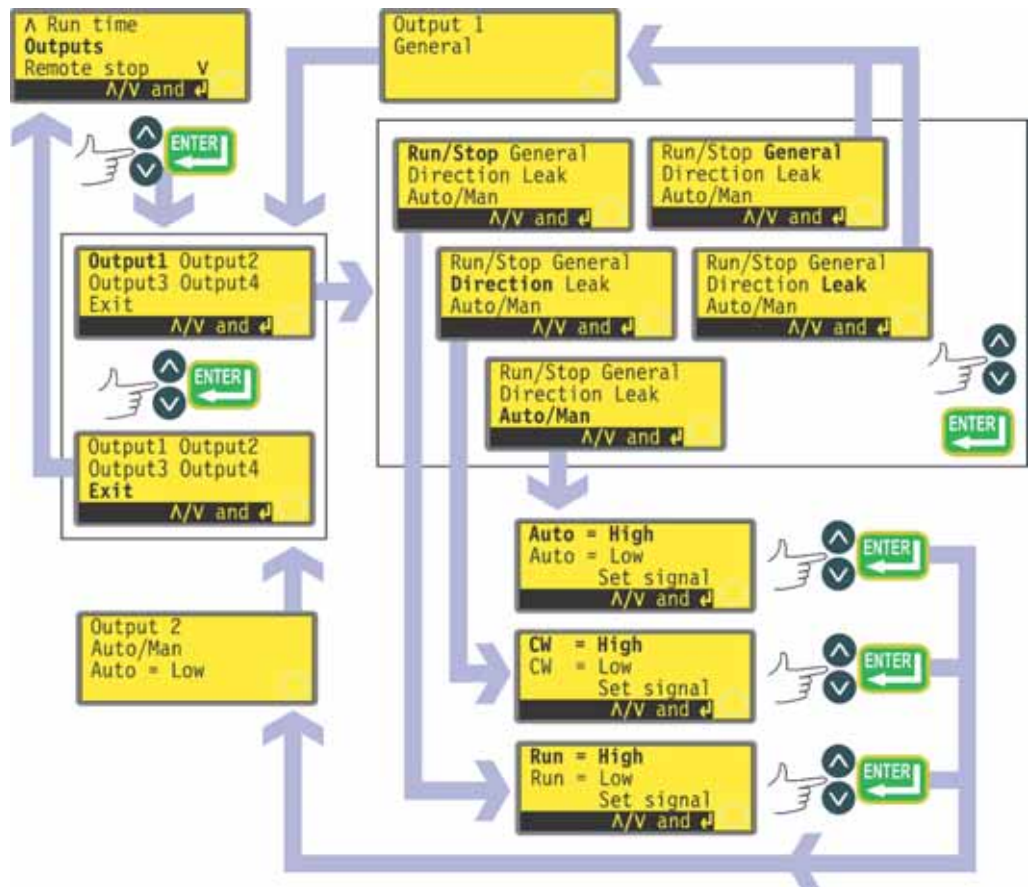

- In the third screen of the Setup menu select **Outputs** using the **UP** and **DOWN** keys. Press **ENTER** to confirm your choice.
- The pump displays a screen allowing you to configure each of the four outputs, or to exit this menu. Use the **UP** and **DOWN** keys to choose and press **ENTER** to confirm your decision.
- If **Output 1** is chosen, the pump displays the five options.
 - Selecting **General** or **Leak** using the **UP** and **DOWN** keys and confirming the choice by pressing **ENTER** configures that option to Output 1, displays a confirmation screen, and returns the user to the Output selection screen.
 - Selecting **Run/Stop**, **Direction** or **Auto/Man** using the **UP** and **DOWN** keys and confirming the choice by pressing **ENTER** displays screens allowing the user to configure Run to **High** or **Low**, Clockwise to **High** or **Low**, and Auto to **High** or **Low** respectively. Choose using the **UP** and **DOWN** keys and press **ENTER** to confirm. The option chosen is configured to Output 1. The pump displays a confirmation screen, and returns the user to the Output selection screen.
- The user can configure **Output 2**, **Output 3** and **Output 4** in the same way, or choose **Exit**.
- If **STOP** is pressed during configuration, the previous setting for the output is retained and the pump redisplay the Output selection screen.
- If **Exit** is chosen, the pump returns the user to the third screen of the Setup menu.

18.11 Remote stop

The 520DuS pump can be controlled with a logic input between 80VAC and 130VAC on the i/p terminal of the Run/stop input.

Note: The keypad **STOP** key overrides remote control. If the keypad **STOP** key has been pressed, the pump cannot be started remotely unless the keypad **START** key is pressed first.

Note: Remote stop control overrides analogue input.

Note: Input must be transformer-isolated and not mains power.

Disabling the remote stop control does not disable other remote controls.

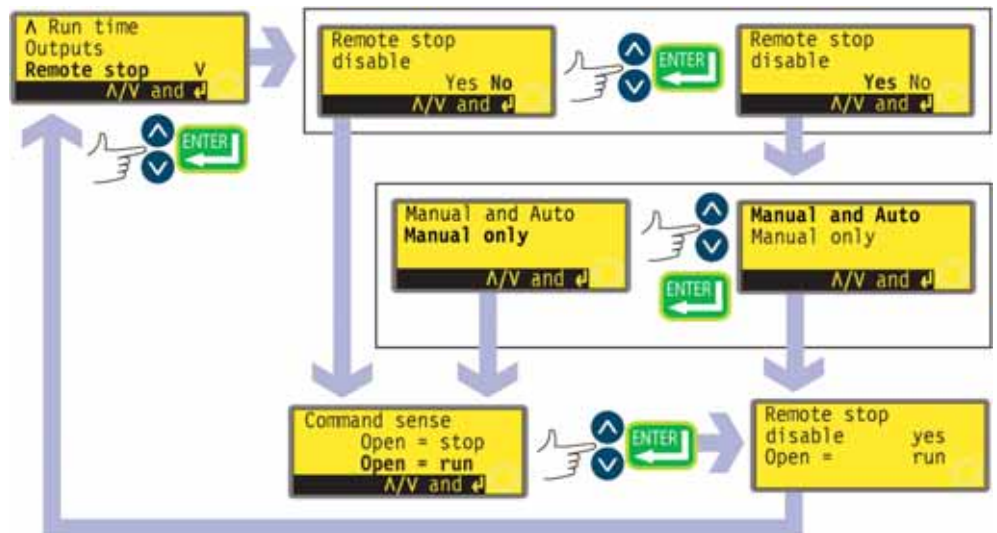

- In the third screen of the Setup menu, select **Remote stop** using the **UP** and **DOWN** keys. Press **ENTER** to confirm your choice.
- The pump displays a screen allowing the user to disable the remote stop feature. Use the **UP** and **DOWN** keys to choose **Yes** or **No** and press **ENTER** to confirm the decision.
- If **No** is chosen, the pump asks the user to make a further choice, according to whether the pump is required to run on an open or closed remote switch: **Open=stop** or **Open=run**. Choose using the **UP** and **DOWN** keys and press **ENTER** to confirm. The pump briefly displays a confirmation screen (an example is shown here) and returns the user to the third screen of the Setup menu.

- If **Yes** is chosen, the pump asks the user whether the remote stop feature is to be disabled fully (for both manual and auto operation), or only for manual operation, leaving remote stop functioning when the pump is operating in auto mode. Choose using the **UP** and **DOWN** keys and press **ENTER** to confirm. If manual and auto was chosen, the pump briefly displays a confirmation screen (an example is shown here) and returns the user to the third screen of the Setup menu. If manual only was chosen, the pump asks the user to make a further choice, according to whether the pump (with remote control available in auto mode only) is required to run on an open or closed remote switch: **Open=stop** or **Open=run**. Choose using the **UP** and **DOWN** keys and press **ENTER** to confirm. The pump briefly displays a confirmation screen (an example is shown here) and returns the user to the third screen of the Setup menu.
- **Note:** The confirmation screen indicates whether Remote stop is enabled or disabled, and displays the command sense of the remote control switch **even if Remote stop has been disabled**.



Even with the remote stop function disabled, the pump could still start if the remote auto/manual toggle input is used to toggle the pump into analogue mode.

Alternatively ...

- To toggle the sense of the remote run / stop control between open=stop and open=run: stop the pump. Turn off the mains power switch at the rear of the pump.
- Hold down the **STOP** key and the **DIRECTION** key, and turn on the mains power switch.
- The pump displays its current state: **Open=stop** or **Open=run**.
- Use the **UP** or **DOWN** keys to switch between the two states.
- Press **START** to accept the new state.

18.12 Auto-restart

This pump offers an auto-restart feature. If active on power loss, it restores the pump when power returns to the operating state it was in when power was lost. It does not operate when powering down in the middle of a dose: when the pump is restarted, it will await a press on the **START** key to begin the interrupted dose again. Auto-restart is retained while the pump is switched off. When the pump starts running, look for the ! symbol on the display. This ! symbol indicates that the pump is set for auto-restart.

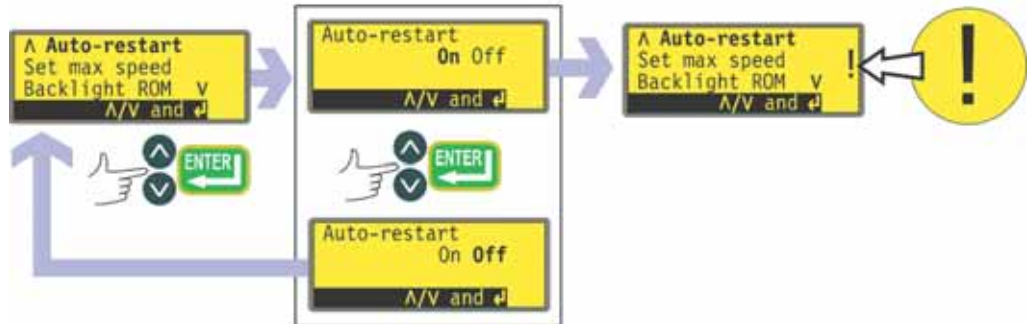

- In the fourth screen of the Setup menu select **Auto-restart** using the **UP** and **DOWN** keys. Press **ENTER** to confirm your choice.
- The pump displays a screen allowing the user to activate auto-restart. Use the **UP** and **DOWN** keys to choose **On** or **Off** and press **ENTER** to confirm the decision.
- If **Off** is chosen, the pump returns the user to the fourth screen of the Setup menu. The auto-restart facility will not operate.
- If **On** is chosen, the pump returns the user to the fourth screen of the Setup menu, where an exclamation mark (!) is now visible. This mark confirms that the auto-restart feature is in place and will operate the next time power is lost and restored.

Alternatively ...

- Stop the pump. Turn off the mains power switch at the rear of the pump.
- Hold down the **START** key and turn on the mains power switch. The ! symbol shows on the display.
- Start the pump. If the mains supply is interrupted the pump will automatically restart when the mains power returns.
- To remove auto-restart switch off the mains power at the rear of the pump. Hold down the **STOP** key and turn the mains power switch on. The ! symbol does not appear.



Do not use auto-restart for more than 100 starts per hour. We recommend remote control where a high number of starts is required.

18.13 Set maximum speed

The 520DuS pump offers a maximum speed of 220 revolutions per minute. This limit can be reduced for operational purposes.



- In the fourth screen of the Setup menu select **Set max speed** using the **UP** and **DOWN** keys. Press **ENTER** to confirm your choice.
- The pump displays a screen allowing the user to set the maximum speed of the pump equal to or lower than the maximum available. Use the **UP** and **DOWN** keys to set the maximum allowed speed and press **ENTER** to confirm the figure.
- The pump returns the user to the fourth screen of the Setup menu.
- Altering the maximum speed automatically re-scales the analogue speed control response.

Note: The maximum speed available depends on the pumphead selected during calibration.

18.14 Backlight

The pump's display can be illuminated or not according to choice.

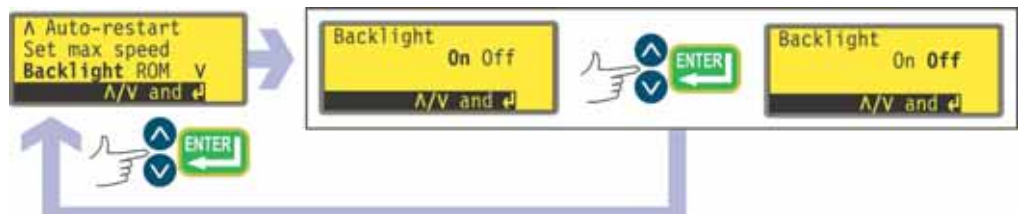

- In the fourth screen of the Setup menu select **Backlight** using the **UP** and **DOWN** keys. Press **ENTER** to confirm your choice.
- The pump displays a screen allowing the user to switch the display backlight on or off. Use the **UP** and **DOWN** keys to choose **On** or **Off** and press **ENTER** to confirm the decision.
- The pump returns the user to the fourth screen of the Setup menu. The display is now illuminated or not according to the user's decision.

Alternatively ...

- To turn the backlight off: press **STOP** and **DOWN** together.
- To turn the backlight on: press **STOP** and **UP** together.

18.15 ROM

The pump can display its software version, model number and pump speed.



- In the fourth screen of the Setup menu select **ROM** using the **UP** and **DOWN** keys. Press **ENTER** to confirm your choice.
- The pump displays the software version, model number and pump speed for four seconds, then returns the user to the fourth screen of the Setup menu. It also displays a checksum: CHK 123, for example. This may be required if reporting pump performance to the Watson-Marlow service department.

Alternatively ...

- Press **REVERSE** and **DOWN** together to interrupt the display and show the pump's ROM version for four seconds.

18.16 Language

The pump can be set to operate in several languages.



- In the fifth screen of the Setup menu select **Language** using the **UP** and **DOWN** keys. Press **ENTER** to confirm your choice.
- In the next screen, choose a language using the **UP** and **DOWN** keys. Press **ENTER** to confirm your choice. The pump redisplay the fifth Setup screen in your chosen language. All screens will subsequently appear in your chosen language.

18.17 Defaults

All the pump's user-set data can be reset to factory defaults.



- In the fifth screen of the Setup menu select **Defaults** using the **UP** and **DOWN** keys. Press **ENTER** to confirm your choice.
- A warning is displayed for four seconds, and the pump asks the user to confirm that factory defaults are to be reset. Use the **UP** and **DOWN** keys to choose **Yes** if you wish the pump to reset all user-set data back to factory defaults (see 12 *Switching the pump on for the first time*); or **No** if you do not wish to do this. Press **ENTER** to confirm your decision. If **Yes** was chosen, the pump will reset its factory defaults and redisplay the fifth Setup screen. If **No** was chosen, the pump will make no changes to its setup and redisplay the fifth Setup screen.

18.18 Beep

The pump keypad can operate silently or indicate a positive key-press with a beep sound.



- In the fifth screen of the Setup menu select **Beep** using the **UP** and **DOWN** keys. Press **ENTER** to confirm your choice.
- In the next screen, use the **UP** and **DOWN** keys to choose **On** or **Off**. Press **ENTER** to confirm your decision. The pump redisplay the fifth Setup screen.

Alternatively ...

To toggle the sound on and off, stop the pump. Turn off the mains power switch at the rear of the pump.

Depress the **UP** and **DIRECTION** keys while switching on the mains power switch at the rear of the pump.

18.19 Security code

Access to the pump's Setup menu, direction control and keypad lock can be restricted to those who correctly enter a three-digit security code: the main code. A secondary user code can be set, which permits PIN access to direction and keypad lock, but blocks access to Setup. See 18 Setup, 14.1 Keypad functions in manual mode and 14.2 Keypad lock.

The code must first be set.

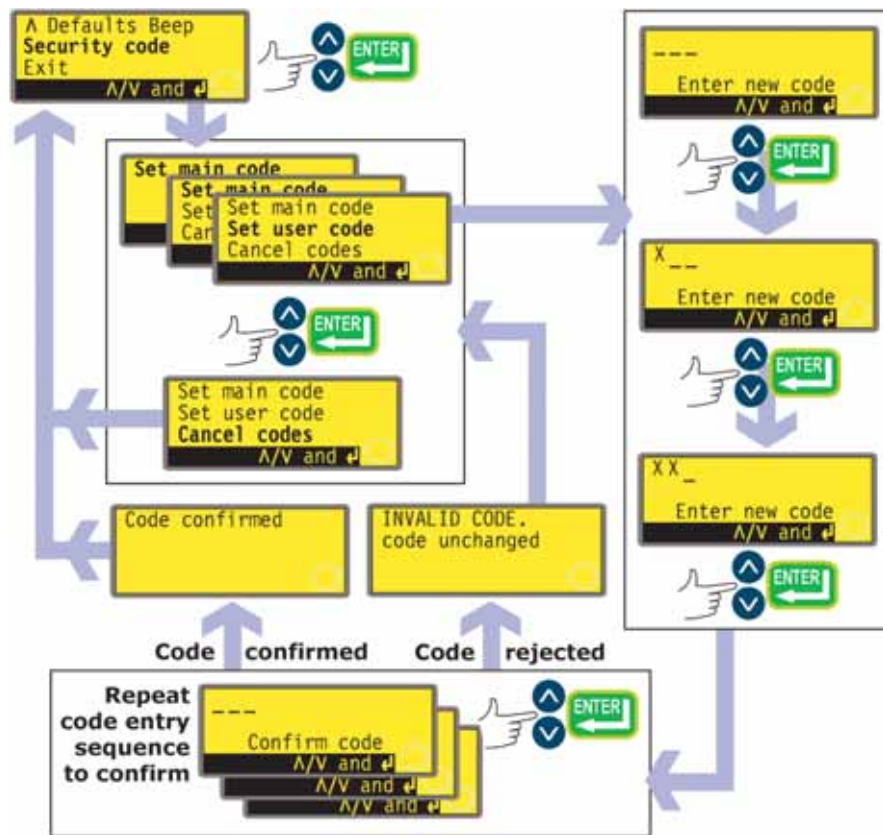

- In the fifth screen of the Setup menu select **Security code** using the **UP** and **DOWN** keys. Press **ENTER** to confirm.
- If no code has been set, a screen is displayed inviting the user to set a main code. Press **ENTER** to proceed (or **STOP** to return to the fifth screen of the Setup menu).
- If a main code has been set, a screen is displayed inviting the user to set a new main code, to set a user code (or a new user code if one has already been set), or to cancel all codes. Choose **Set main code**, **Set user code** or **Cancel codes** using the **UP** and **DOWN** keys. Press **ENTER** to confirm your choice.

- If you chose **Cancel codes**, any codes previously set are cancelled and access to the pump is not restricted.
- If you chose **Set main code** or **Set user code**, the pump displays a screen with three blank spaces for digits and the instruction "Enter new code". Use the **UP** and **DOWN** keys to enter three digits. Press **ENTER** to confirm each one. The pump displays a similar three-digit entry screen and the instruction "Confirm code".
- Repeat the digit-entry sequence.
- If the second three-digit code entered differs from the first, or if the digits chosen as a user code are the same as those already set as a main code, the pump briefly displays an error message and redisplay the set code options screen.
- If the codes tally and, for a user code, if there is no clash with a previously set main code, the pump briefly displays a confirmation message and redisplay the sixth Setup screen. Access to the Setup and Configuration menus, Dose, direction control and keypad lock is now protected by the new security code.
- If **STOP** is pressed during code entry, the pump returns the user to the fifth Setup screen. If **STOP** is pressed during code confirmation, the pump returns the user to the first digit-entry screen.

Note: A user code cannot be set unless a main code has previously been set. If you wish to cancel only a user code, you must use **Cancel codes** to cancel both user and main codes, then use **Set main code** to set a new main code.

Note: If a code has been set but forgotten, it is still possible to access the Setup screens to cancel the code or reset it to another three-digit number. Contact your supplier or Watson-Marlow Technical support for the bypass sequence.

18.20 Exit



- In the sixth screen of the Setup menu **Exit** is highlighted. Press **ENTER**.
- The user is returned to the main menu.

19 Pin out details

Pin out information is not relevant to the 520DuS NEMA 4X pump. Selecting **Pin out details** causes the pump to display a warning screen and redisplay the main menu.

20 MemoDose

Each time the pump is started by pressing **START**, it records the number of pump-head revolutions which occur until **STOP** is pressed. The number of revolutions is proportional to the volume of fluid which has been dispensed: the dose. The MemoDose facility allows the user to repeat-dose a precise volume of fluid. To do so, a quantity of fluid must be dispensed as the master dose which the MemoDose facility can repeat exactly or proportionately.

To dispense a master dose

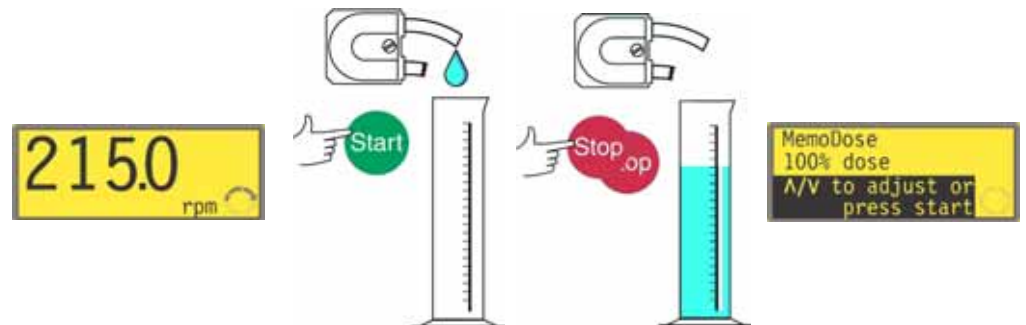

- In the manual mode main screen, set the appropriate pump speed and direction using the **UP** or **DOWN** keys and the **DIRECTION** key. An example is shown here. A slower speed may make it easier for the user to measure accurately - though it may not represent the duty condition.
- Place a suitable measuring vessel under the pump delivery tube.
- Press **START**. The pump runs and fluid is pumped into the vessel.
- When the required volume of fluid has been dispensed, it is necessary to stop the pump and display the MemoDose screen. This can be achieved in three ways.
 1. Press the **STOP** key twice within half a second. The pump stops and immediately displays the MemoDose screen.
OR...
 2. Press the **STOP** key once. The pump stops. (This may make it easier to ensure that the quantity of fluid that has been dispensed is sufficiently precise.) Then press the **STOP** key twice within half a second. The pump displays the MemoDose screen.
OR ...
 3. Press the **STOP** key. The pump stops. Press the **MENU** key. Use the **UP** or **DOWN** keys to select **MemoDose**. Press **ENTER** to confirm. The pump displays the MemoDose screen.

To repeat the dose

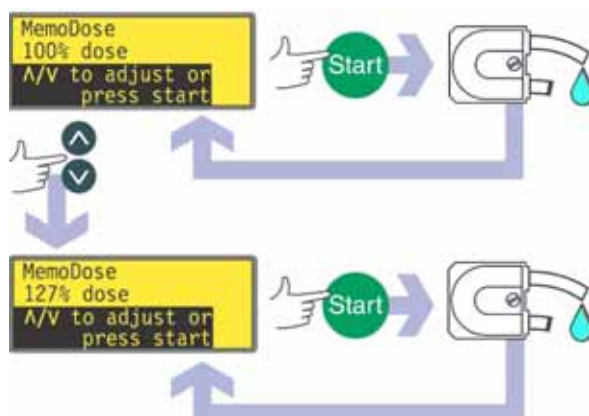

- The pump has recorded the number of pumphead revolutions required to dispense the master dose. If the volume of fluid in the measuring vessel is the volume required, press **START** to repeat the dose.
- If the volume of fluid in the measuring vessel differs from the volume required, the percentage may be adjusted within the limits 1% to 999% of the master dose. Use the **UP** or **DOWN** keys to alter the percentage. Press **START** to dispense the new dose.
- The display counts down as the dose proceeds and stops when the dose is complete.
- If **STOP** is pressed during dosing, the pump stops and returns the user to the MemoDose percentage screen.

Press the **STOP** key twice within half a second if you wish to exit MemoDose and return to manual operation.

20.1 Changing dosing speed

The user must exit MemoDose in order to change pump speed (and direction). After returning to MemoDose, the pump dispenses the previous dose size at the new speed.



- Press the **STOP** key twice within half a second. The pump displays the manual mode main screen.
- **Do not start the pump. Doing so erases the previously recorded master dose and replaces it in the pump's memory with the current, unmeasured dose.** Adjust the speed showing on the display using the **UP** or **DOWN** keys.

- Press the **STOP** key twice within half a second to return to MemoDose. The display shows the previous percentage dose size. The pump will dose at the new speed.

Note: To retain the MemoDose value through a power interruption the pump must be in auto-restart mode. The dosing cycle will resume at the start of a dose and wait for **START** to be pressed, with the MemoDose percentage screen displayed. See 18.12 *Auto-restart*.

20.2 Footswitch operation and other remote inputs and outputs with MemoDose

A footswitch or a momentary contact switch can be used to trigger MemoDose dispensing as a hands-free alternative to pressing **START**.

Apply a momentary signal of 80VAC to 130VAC across the terminals of the Dose input connector (J3) to trigger a dose. Polarity is not important.

To operate MemoDose with a footswitch, briefly press the footswitch while the MemoDose percentage screen is displayed.

The remote run / stop input is operational. If a dose is interrupted by a remote stop signal, the dose will continue from where it stopped when the state is changed to run.

Remote direction control is disabled. The leak-detection input is operational. All status outputs are operational.

Note: The keypad lock feature is particularly useful to prevent inadvertent dose changes while using the MemoDose facility. Keypad lock continues to operate in MemoDose if previously enabled; it can also be enabled while in MemoDose mode. See 14.2 *Keypad lock*.

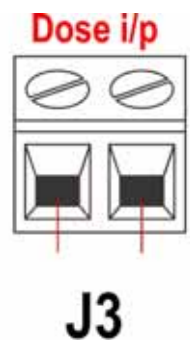

21 Exit

Press **Exit** in the Main menu to return to the Manual mode main screen.

22 Automatic control wiring

Interfacing the pump with other devices is by means of screw-terminal connectors within the 520N SCADA module at the rear of the pump. Suitable cable must be passed into the module through one or more watertight cable glands and connected appropriately. The module must be removed to allow this.



It is important to check the pump's voltage setting to ensure that it matches the supply. The voltage selection switch is on the rear panel of the drive. The module must be removed (and replaced) to allow it to be checked.

22.1 520N module removal and replacement

To remove the 520N watertight module:

The module is secured to the back of the drive unit by six M5x12 Pozidriv counter-sunk stainless steel screws.



- Remove the six screws using a suitable crosspoint screwdriver, leaving the top centre screw till last. Even when all screws have been removed, the sealing strip may cause the module to adhere to the drive. If so, a gentle tap will free it. Do not use a tool to lever it off.
- The sealing strip should be retained within its channel on the face of the module. The transparent on/off switch cover should be retained on its flange on the face of the module. Check the integrity of the seal and the transparent on/off switch cover. If either is damaged, it must be renewed to maintain ingress protection.

- If necessary, unplug the two 25-way D-connectors linking the module to the pump drive. If necessary, remove the module's earth link from the back of the drive. However, the link is long enough to allow the module to fold back to give access to the the circuit board inside and to the back of the drive.

To replace the 520N watertight module:



- Check that the fuse in the fuseholder (ringed) in the centre of the switchplate does not need to be replaced. Check that the voltage selector switch is correctly set for your power supply.
- Check that the sealing strip is fully in its channel on the face of the module.
- Attach the module's earth link wire. Replace and tighten its screw to 2Nm.
- Push home the female (upper) and male 25-way D-connectors on to their counterparts on the rear of the drive.
- Hold the module in place, taking care not to disturb the seal or pinch the earth link wire or D-connector ribbon cables, and screw in the six retaining screws (top centre screw first). Tighten to 2.5Nm.

Note: Ensure that the 520N module is properly fitted at all times using all six screws. Without the module and the screws, the screw holes may corrode and IP66 (NEMA4X) protection will be compromised.

22.2 Wiring up

It is the user's responsibility to ensure the pump's safe and reliable operation under remote and automatic control.

The 0V lines on this pump are commoned and mains transformer-isolated from ground (floating ground). It can be connected to isolated 0V or grounded 0V interfaces.

Cable entry to the module is via up to four watertight cable glands. These may be fitted in place of the sealing plugs which are fitted to the back of the module when the pump is shipped.



The number of glands needed depends on the number of connection cables required and the convenience of the installer. As standard, four M16 cable glands are provided with the pump.

Recommended control cable conductors for the terminal blocks: metric = 0.14sq mm - 2.5sq mm solid and 0.14sq mm - 1.5sq mm stranded. USA = 26AWG - 14AWG solid and 26AWG - 16AWG stranded. Cable: circular. Max/min outside diameter to ensure a seal when passed through the standard gland: 9.5mm-5mm. **The cable section must be circular to ensure a seal.**

For EMC protection, shielded control cable should be used. The shielding should be terminated to one of the pcb mounting screws or to the adjacent spade connection (where fitted).

For improved EMC protection in extremely noisy environments, shielded cable may be used in conjunction with watertight EMC metal cable glands. These must be earthed to the module by adding an M16x1.5 nut with serrated edges to ensure proper contact with the inside of the module. It is necessary to remove the module's circuit board to access the interior of the module: it is held in place by two fixing screws which can be removed and replaced with a cross-point screwdriver. Take normal anti-static precautions when handling printed circuit boards.

Suitable cables for general-purpose use: 300V with extra premium grade PVC jacket with good flame and moisture resistance.

Suitable cables for industrial use: 300V extra-rugged polyurethane grade jacket with resistance to oils, fuels, solvents and water.

For convenience of wiring more than 8 conductors per cable may be awkward to handle. Only two appear in the illustrations here, for clarity.

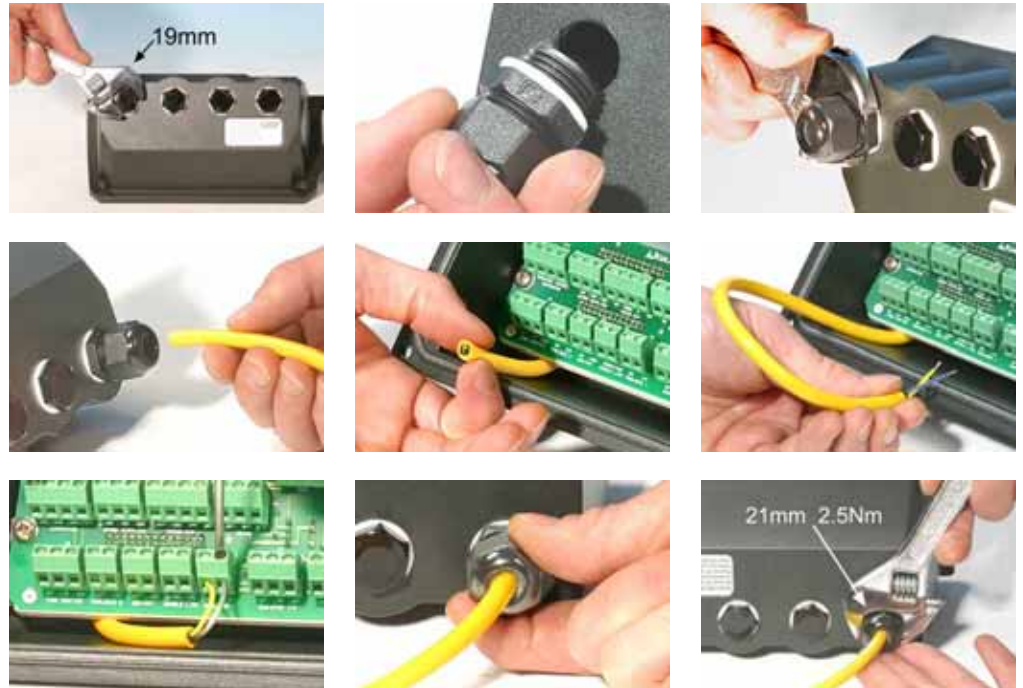

- Use a 19mm spanner to unscrew the sealing plug. Discard the nylon sealing washer.
- Screw in one of the supplied M16x1.5 cable glands in place of the plug, using the new nylon sealing washer supplied. Tighten the gland to 2.5Nm to ensure a seal, using a 21mm spanner. If a different gland is used, it must be watertight to IP66.
- Loosen the gland cap (do not remove it) and pass the cable in through the gland. When it has passed through the gland, continue to push the cable through.
- The inside of the module is shaped to guide the cable past the printed circuit board inside. Continued pushing will feed in enough cable to grip inside the module with the fingers.
- Pull through sufficient cable to reach the connectors required. Leave a little slack.

- Strip the outer sheath as necessary and remove 5mm of insulation from the conductors. No tinning or ferrule is required. **Note:** If very stiff or large-diameter cable is used, it may be convenient to strip the outer sheath before passing the cable's conductors through the gland. However, to ensure a seal, cable with an undamaged sheath must be present within the gland when it is tightened.
- Twist a suitable length of the cable screen. Loosen one of the pcb retaining screws and wind the shielding round it. Secure the screen by refastening the screw. Alternatively, secure the cable screen to the adjacent spade connection (where fitted).
- Push the bared conductor into the square hole in the connector. When the conductor is fully in, tighten the retaining screw to hold it in place.
- When all conductors are in position, use a 21mm spanner to tighten the gland cap to 2.5Nm to ensure a seal. Alternatively, tighten the gland by hand until it is finger-tight and use a spanner to tighten it further by one-half a turn.

Do not strap the control and mains power cables together.

520N SCADA module pcb connectors:

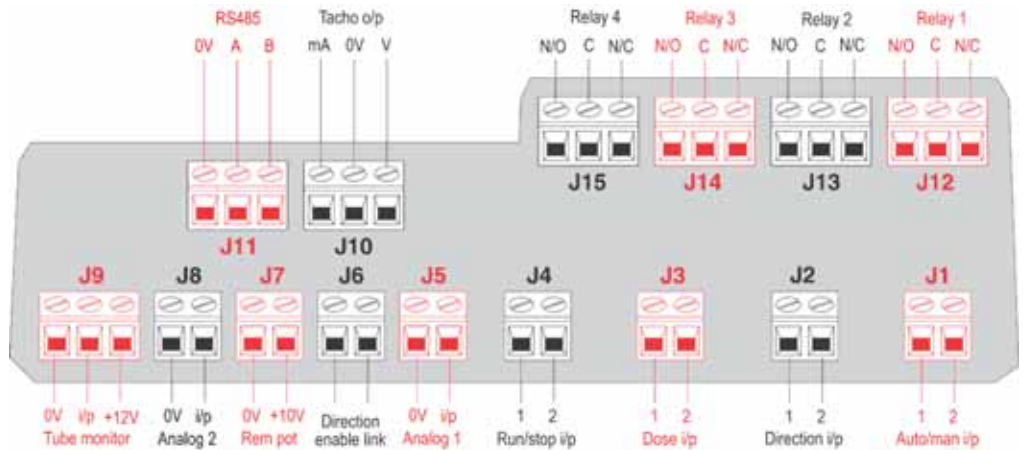

Note: 0V connections on J9, J8, J7, J5 and J10 within the 520N module are commoned. Only one 0V connector is needed when using a common source, and no internal hard links are required.



Never apply mains power to the terminals within the 520N SCADA module. Apply the correct signals to the terminals shown below. Limit signals to the maximum values shown. Do not apply voltage across other terminals. Permanent damage, not covered by warranty, may result. The maximum load on the relay contacts of this pump is 130VAC; maximum current 2A; 1A max at 60VDC. Do not apply mains power to the relays; all voltage supplies must be transformer-isolated.

22.3 Speed: analogue input 1

It is possible to control the speed of the pump remotely by one of these methods: a voltage analogue signal within the range 0-10V; or a current analogue signal within the range 4-20mA; or a remote potentiometer using the **10V** supply at J7.

The analogue process signal must be applied to the **i/p** terminal of the Analogue 1 connector (J5). Ground to the **0V** terminal of the same connector. The pump will provide an increasing flow rate for a rising control signal (non-inverted response) or an increasing flow rate for a falling control signal (inverted response). See 18.2 *Analogue*.

4-20mA circuit impedance: 250Ω.

For voltage mode, 0-10V, a stable, reliable voltage source can be used with a DC voltmeter. Circuit impedance: 22kΩ.

Inverting the response is set up in software. Do not invert the polarity of the terminals.

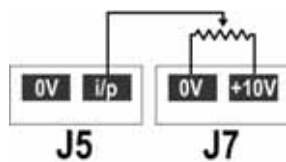

A remote potentiometer with a nominal value of between 1k and 2k with a minimum of 0.25W should be wired between the terminals of the Rem-pot connector (J7) and the **i/p** terminal of the Analogue 1 connector (J5). When

using a remote potentiometer, do not apply a voltage or current control input signal at the same time. The speed control signal will require calibration relative to the minimum and maximum settings of the potentiometer. This is done in software - see 18.1 *Trim*.

When using a remote potentiometer, it is important to set the analogue input to voltage in the Setup menu. Otherwise the reference voltage supply from the Rem-pot connector will be overloaded and will not provide a full 10V.

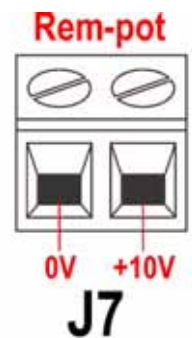
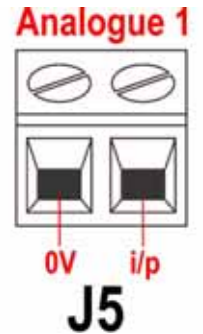

22.4 Scaling: analogue input 2

It is possible to scale the speed of the pump remotely by one of these methods: a voltage analogue signal within the range 0-10V; or a current analogue signal within the range 4-20mA; or a remote potentiometer using the **10V** supply at J7.

The analogue process signal must be applied to the **i/p** terminal of the Analogue 2 connector (J8). Ground to the **0V** terminal of the same connector.

4-20mA circuit impedance: 250Ω.

For voltage mode, 0-10V, a stable, reliable voltage source can be used with a DC voltmeter. Circuit impedance: 22kΩ.

Inverting the response is set up in software. Do not invert the polarity of the terminals.

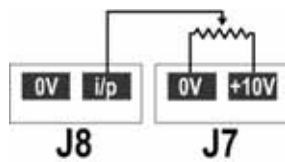

A remote potentiometer with a nominal value of between 1k and 2k with a minimum of 0.25W should be wired between the terminals of the Rem-pot connector (J7) and the **i/p** terminal of the Analogue 2 connector (J8). When

using a remote potentiometer, do not apply a voltage or current input signal at the same time. The scaling control signal will require calibration relative to the minimum and maximum settings of the potentiometer. This is done in software - see 18.1 *Trim*.

When using a remote potentiometer, it is important to set the analogue input to **voltage** in the Setup menu. Otherwise the reference voltage supply from the Rem-pot connector will be overloaded and will not provide a full 10V.

The speed of the pump as set by Analogue 1 is scaled in proportion to the signal from Analogue 2 according to the formula $y=as$, where a is the speed set by Analogue 1, s is the scaling set by Analogue 2 (0V or 4mA = 0, increasing linearly to 10V or 20mA = 1), and y is the scaled rotation speed. If Analogue 2 has been set for an inverted response, the reverse is true. See 18.2 *Analogue*.

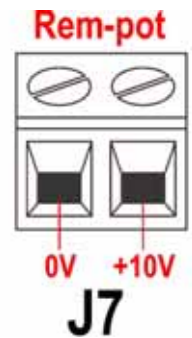
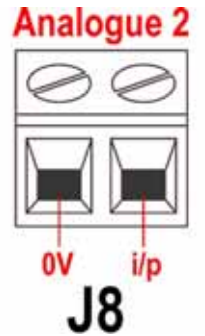

22.5 Speed: analogue output

An analogue voltage output signal is available on the Tacho output connector (J10). A voltage analogue signal within the range 0-10V is available between the **V** terminal and the **0V** terminal. The voltage is fixed and directly proportional to the pumphead rotation speed. 0V = zero speed; 10V = maximum speed.

A current analogue signal within the range 4-20mA is available between the **mA** terminal and the **0V** terminal. The current is fixed and directly proportional to the pumphead rotation speed. 4mA = zero speed; 20mA = maximum speed.

Note: If the mA output is to be used for reading from a multimeter, a 250Ω resistor is required in series.

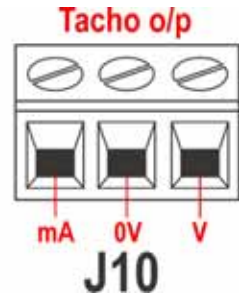

Important: general instructions for remote control inputs

All remote control inputs can be wired in two ways:

Logic

A logic voltage between 80VAC and 130VAC may be wired to the input. The pump is configured to operate without modification anywhere in this range. Each of the four logic inputs is opto-isolated. Terminal 1 is the common or return. Terminal 2 is the signal. Logic low is equivalent to no voltage and logic high to 80-130VAC. Polarity is not important. It is possible to common all the inputs - J1, J2, J3 and J4, terminals 1 OR terminals 2 - to the same 0V line.

Switch

A remote switch may be connected between the input and any voltage supply between 80VAC and 130VAC. Polarity is not important.

22.6 Run / stop input

Remote run / stop: apply a signal of 80VAC to 130VAC across the terminals of the Run/stop input connector (J4). Polarity is not important. See 14.4 *Manual operation and remote digital inputs and outputs*. To change or set the sense of the run / stop input, see 18.11 *Remote stop*.

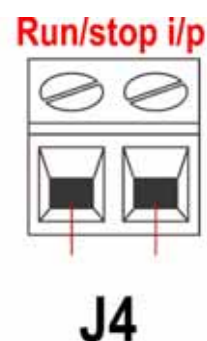

22.7 Direction input

To enable remote direction control and disable the **DIRECTION** key on the keypad, link the terminals of the Direction enable link connector (J6). **Important: Apply no voltage whatever to the Direction enable link (J6).** Apply a signal of 80VAC to 130VAC across the terminals of the Direction input connector (J2) for counter-clockwise rotation. Polarity is not important. With no signal, the pump will rotate clockwise.

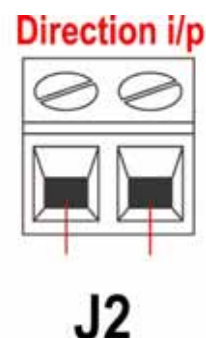
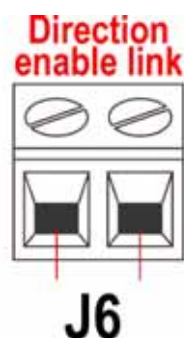

22.8 Auto / manual toggle input

Apply a signal of 80VAC to 130VAC across the terminals of the Auto-man input connector (J1) for analogue control. Polarity is not important. With no signal, the pump is subject to manual control. Polarity is not important.

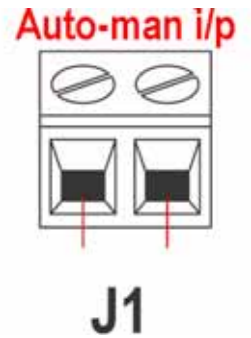

22.9 MemoDose input

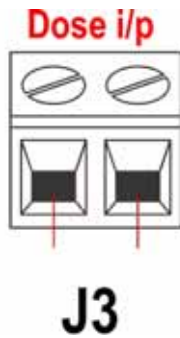

Apply a momentary signal of 80VAC to 130VAC across the terminals of the Dose input connector (J3) to trigger a dose. Polarity is not important.

Note: This input is software-debounced, so the signal can be either momentary or maintained during the dose. If maintained, the signal must be removed before the next dose.

22.10 Leak detection input

Connect a remote leak-detection device between the **+12V** terminal and the **i/p** terminal on the Tube monitor connector (J9). Closed circuit indicates a leak. Alternatively a logic input may be applied to the **i/p** terminal, ground to the **0V** terminal. High input indicates a leak. Connect the cable of a Watson-Marlow Tube monitor leak detector as follows:

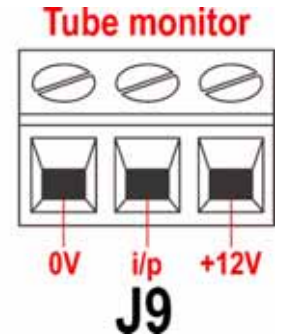

Tube monitor wire colour	520N module
Blue	J9 0V terminal
Yellow	J9 i/p terminal
Red	J9 +12V terminal
Terminate the screen in the 520N module with a 360° EMC gland if required. See 22.2 <i>Wiring up</i> .	

Note: Use only Watson-Marlow 520 series tube monitors.

Important: pump status outputs

Outputs 1-4 are available as single-pole change-over relay contacts: Relay 1, 2, 3 and 4. Connect to the normally open or normally closed contacts of the relay as required and configure the pump's software accordingly. See 18.10 *Outputs*.

Note: The maximum load on the relay contacts of this pump is 130VAC; max current 2A; 1A max at 60VDC. Voltages do not require transformer isolation. The relays are specified to switch 115VAC mains powered loads. These relay outputs are not recommended for 5VDC logic signals.

22.11 Outputs 1, 2, 3, 4

Note: Relay 1 (J12) is represented here. Relay 2, Relay 3 and Relay 4 (J13, J14 and J15) function identically.

Connect your output device to the **c** (common) terminal of your chosen relay connector and either the **n/c** terminal or the **n/o** terminal (normally closed or normally open) as required. Configure the pump's software accordingly. See 18.10 *Outputs*.

By default, Relay 1 is configured to indicate Run/Stop status; Relay 2 is configured to indicate Direction status; Relay 3 is configured to indicate Auto/man status; Relay 4 is configured to indicate General alarm status. See 12 *Switching the pump on for the first time*.

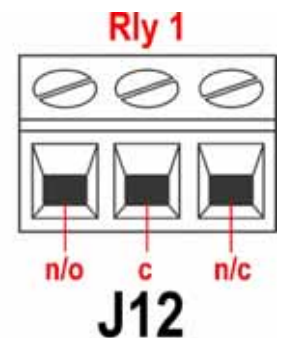

22.12 RS485 input

Connect your network link to J11 using a screened twisted pair: A to A, B to B, screen to 0V. Ensure that the pump is configured to operate under Network control. More than one pump may be controlled with the same RS485 signal: connect all pumps in parallel. See 24 *Network control and operation*.

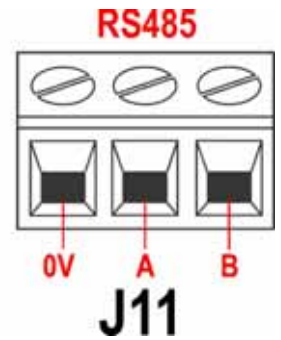

23 Automatic control and operation

Check that the pump is ready to run before selecting automatic operation. Remote control signals may start the pump without warning.

How to get into auto operation

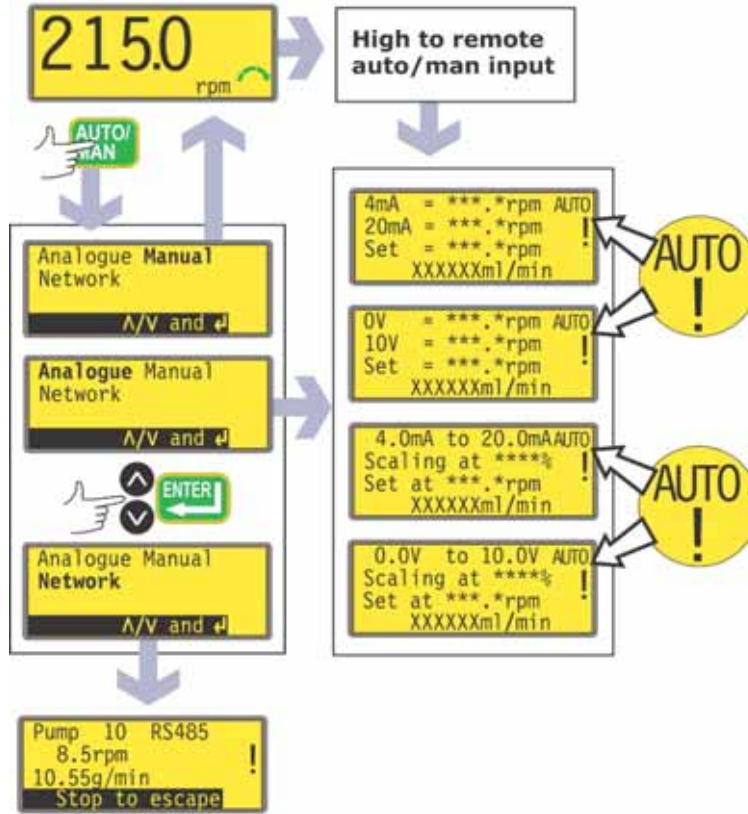

- While the manual mode main screen is displayed, press the **AUTO/MAN** key, or apply a high signal (80VAC to 130VAC) to the remote auto / manual input.
- If auto entry was triggered remotely, the pump responds to the analogue signal as soon as this is done and shows the "AUTO" icon.
- If auto entry was triggered using the **AUTO/MAN** key, the pump offers three choices: **Analogue**, **Manual** and **Network**. Use the **UP** and **DOWN** keys to choose and press **ENTER** to confirm.
 - Selecting **Manual** returns the user to the manual mode main screen. See 14 *Manual operation*.
 - Selecting **Network** puts the pump into network (RS485) mode. See 24 *Network control and operation*.
 - Selecting **Analogue** puts the pump into analogue mode. It responds to the analogue signal as soon as this is done and shows the "AUTO" icon.

- The pump is automatically switched into auto-restart mode and displays the ! icon. The only keys active are **STOP**, **AUTO/MAN**, **DIRECTION** and **START** (available only as an extended keypress to toggle keypad lock). **UP** and **DOWN** keys are available if manual scaling has been set (see below).
- If the remote direction input is active and the direction-enable link is applied, the **DIRECTION** key is disabled. If keypad lock is set, only **STOP** and **START** (available as an extended keypress to toggle keypad lock) are active.
- The pump displays whichever of four auto running screens is appropriate according to the previously selected auto mode - 4-20mA or 0-10V with or without scaling in place.
- The auto running screens display four pieces of information: the speed at which the pump rotates after receiving a low signal on Analogue 1 (4mA or 0V); the speed at which the pump rotates after receiving a high signal on Analogue 1 (20mA or 10V); the set speed (that is: the speed at which the pump is currently rotating according to the analogue speed signal and the analogue scaling signal if scaling is set); and the flowrate in the units selected (see 18.8 *Flow units*). The scaling percentage is also displayed if it is set.
- If manual scaling is enabled using the Setup menu (see 18 *Setup*), the scaling percentage can be adjusted between 0% and 100% using the **UP** and **DOWN** keys.
- The pump responds to remote digital inputs. If the run / stop input stops the pump, the bottom line of the auto running screen shows "Remote stop". When it starts the pump again, this will disappear and the pump returns to normal running mode.
- If the pump is stopped because a leak is detected, the screen displays "LEAK DETECTED. Check and reset, then press Stop". See 25.1 *Error codes*.
- The remote status outputs operate fully.

How to get out of auto operation

- Pressing the **AUTO/MAN** key displays three options: **Analogue**, **Manual** and **Network**. Use the **UP** and **DOWN** keys to choose and press **ENTER** to confirm.
 - Selecting **Manual** returns the pump to manual operation. Using this method of changing from **AUTO/MAN**, the pump retains the set speed from its previous operation in manual mode in a stopped condition. See 14 *Manual operation*.
 - Selecting **Network** puts the pump into network (RS485) mode. See 24 *Network control and operation*.
 - Selecting **Analogue** returns the pump to analogue mode. It responds to the analogue signal as soon as this is done and shows the "AUTO" icon.
- Alternatively, make the remote auto / manual input go low (0V). The pump returns to manual operation and retains the set speed and run status from its previous operation in analogue mode.

Emergency stop

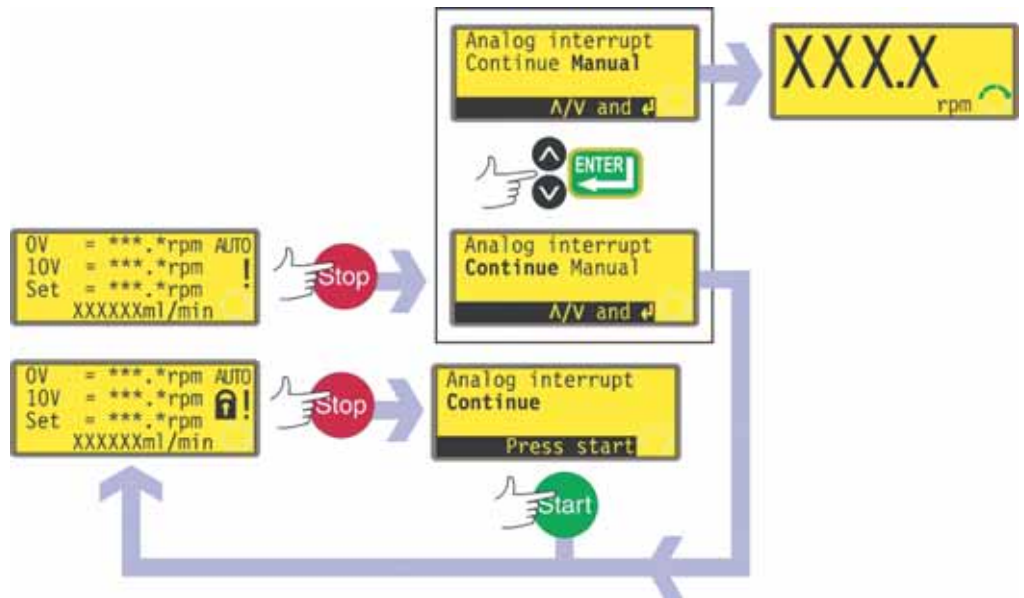

- In an emergency press the **STOP** key. The pump stops and displays an interruption screen.
- If keypad lock is in place when **STOP** is pressed, or if the pump is in auto mode via the digital input, the interruption screen offers one key-press: press **START** to continue auto operation.
- If keypad lock was not in place when **STOP** was pressed, the interruption screen offers a choice: **Continue** to continue auto operation, or **Manual** to switch to manual mode. Use the **UP** and **DOWN** keys to choose and press **ENTER** to confirm.

24 Network control and operation

Check that the pump is ready to run before selecting network operation. Remote control signals may start the pump without warning.

How to get into network operation

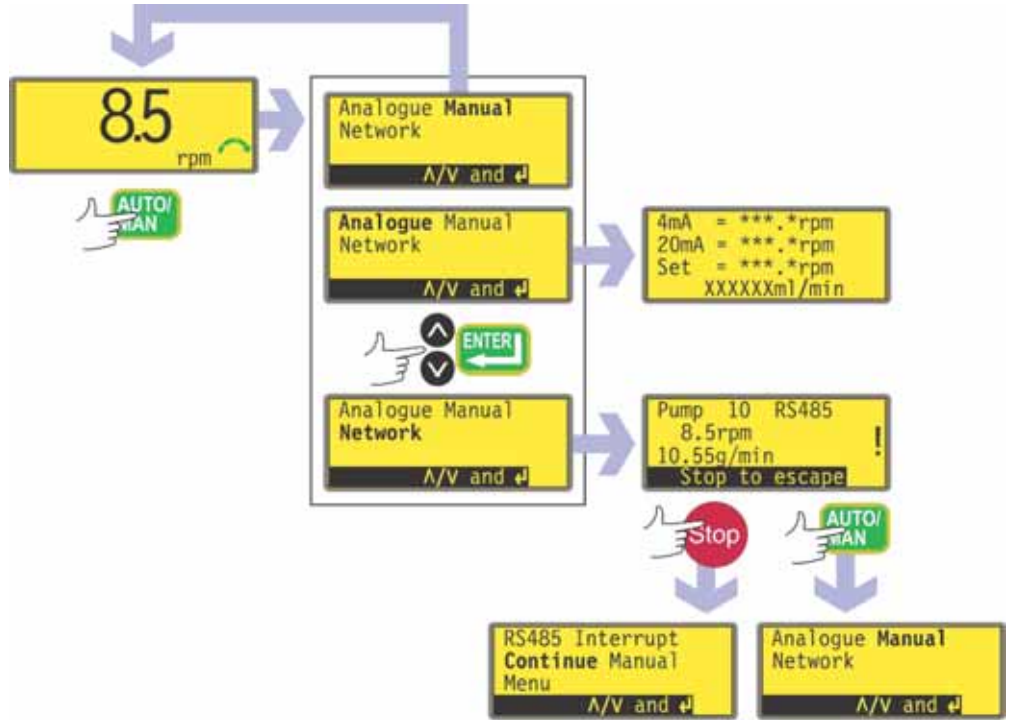

- While the manual mode main screen is displayed, press the **AUTO/MAN** key.
- The pump offers three choices: **Analogue**, **Manual** and **Network**. Use the **UP** and **DOWN** keys to choose and press **ENTER** to confirm.
- Selecting **Manual** returns the user to the manual mode main screen. See 14 *Manual operation*.
- Selecting **Analogue** puts the pump into analogue mode. See 23 *Automatic control and operation*.
- Selecting **Network** puts the pump into network (RS485) mode.
 - The pump is automatically switched into auto-restart mode and displays the **!** icon. The only keys active are **STOP**, **AUTO/MAN** and **MENU**.
 - Remote stop, auto/man, dose, direction enable and direction inputs are inactive. Leak input is active. See 25.1 *Error codes*.
 - All pump status outputs are active.

How to get out of network operation

- Pressing the **AUTO/MAN** key displays three options: **Analogue**, **Manual** and **Network**. Use the **UP** and **DOWN** keys to choose and press **ENTER** to confirm.
 - Selecting **Manual** sets the pump to manual operation and retains the set speed and run status from its previous operation in network mode. See 14 *Manual operation*.
 - Selecting **Network** returns the pump to network (RS485) mode.
 - Selecting **Analogue** sets the pump to analogue mode. See 23 *Automatic control and operation*.

Emergency stop

- In an emergency press the **STOP** key. The pump stops and displays an interruption screen, from which select **Continue** to return to network control, **Manual** to set the pump to manual control (see 14 *Manual operation*), or **Menu** to display the main menu (see 15 *Main menu*). Use the **UP** and **DOWN** keys to choose and press **ENTER** to confirm.

24.1 RS485 command strings

Command	Parameters	Meaning
nCA	-	Clear LCD display
nCH	-	Home the cursor
nDO	xxxxxxxxxx<,yyyyy>	Set and run one dose of xxxxxxxxxxxx tachometer pulses, with optional drip of yyyyy (maximum 11,000) tachometer pulses. See note 1
nTC	-	Clear the cumulative tachometer count
nSP	xxx.x	Set speed to xxx.x rpm
nSI	-	Increment speed by 1rpm
nSD	-	Decrement speed by 1rpm
nGO	-	Start running
nST	-	Stop running
nRC	-	Change direction
nRR	-	Set direction to clockwise
nRL	-	Set direction to counter-clockwise
nRS	-	Return status. See note 2
nRT	-	Return the cumulative tachometer count
nW	[line 1]~[line 2]~ [line 3]~[line 4]@	Display text on 1 to 4 lines with ~ as the line delimiter. Terminated by the @ character. See note 3
nZY	-	Return 0 for stopped or 1 for running

Note 1: The correlation between tachometer pulses and motor rotation is fixed and provides a measurable and absolute way of monitoring the number of revolutions of the gearbox output shaft - 10,982 pulses per revolution. This in turn allows the count to be equated to the amount of material dispensed - assuming that the pumphead type and tube size are known.

Note 2: The status is returned to the sender in the following format: [pump type] [ml/rev] [pumphead] [tube size] [speed] [CW/CCW] P/N [pump number] [tachometer count] [0/1 (stopped/running)] !

For example: 520Du 15.84 520R 9.6MM 220.0 CW P/N 1 123456789 1 !

Note 3: If the pump speed is changed subsequently, the pump must display the screen shown here (example figures only) for 4 seconds before reverting to the custom display. 1 to 4 lines of text can be written with ~ as the line delimiter and @ as the message end.

i.e., 1W520Du@ and 1W520Du~@ are both valid commands.

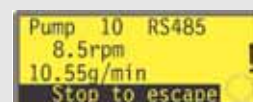

Note 4: In all cases 'n' can be any number from 1 to 32 inclusive, and by exception the # symbol can be used as an all-drives command; but not with the RS, RT or ZY commands, as the results would be indeterminate.

25 Troubleshooting

If the pump display remains blank when the pump is on, make the following checks:

- Check the position of the voltage selector switch. The voltage selector is mounted in the switchplate at the rear of the pump, protected from water by the 520N module. The module must be removed to allow access to the switchplate. See 22.1 *520N module removal and replacement*.
- Check the mains power switch at the rear of the pump.
- Check that mains power is available to the pump.
- Check the fuse in the fuseholder in the centre of the switchplate at the rear of the pump.
- Check the fuse in the mains power plug if one is present.

If the pump runs but there is little or no flow, make the following checks:

- Check that the tube and rotor are in the pumphead.
- Check that fluid is supplied to the pump.
- Check that the tube is not split or burst.
- Check for any kinks or blockages in the lines.
- Check that any valves in the lines are open.
- Check that the correct wall-thickness tube is being used.
- Check direction of rotation.
- Check that the rotor is not slipping on the drive shaft.

25.1 Error codes

If an internal error occurs, a flashing error screen is displayed. **Note: Signal out of range, Over signal, No signal and Leak detected** error screens report the nature of an external signal. They do not flash.

Error condition	Suggested action
RAM write error	Attempt to reset by switching power OFF / ON. Or seek support
RAM corruption	Attempt to reset by switching power OFF / ON. Or seek support
OTP ROM error / corruption	Attempt to reset by switching power OFF / ON. Or seek support
OTP ROM read error	Attempt to reset by switching power OFF / ON. Or seek support
Unknown pump type	Check the interface card and cables. Attempt to reset by switching power OFF / ON. Or seek support
Display failure	Seek support
Wrong key-press	Attempt key-press again. Attempt to reset by switching OFF / ON
Motor stalled	Stop pump immediately. Check pumphead and tube. Power OFF/ON may reset. Or seek support
Tacho fault	Stop pump immediately. Power OFF/ON may reset. Or seek support
Speed error	Stop pump immediately. Power OFF/ON may reset. Or seek support
Over current	Stop pump immediately. Check system. Power OFF/ON may reset. Or seek support
Over voltage	Stop pump immediately. Check mains voltage selector switch. Check supply. Power OFF/ON may reset. Or seek support
Under voltage	Stop pump immediately. Check mains voltage selector switch. Check supply. ON/OFF may reset. Or seek support
Watchdog error	Attempt to reset by switching power OFF / ON. Or seek support
Over temperature	Stop pump immediately. Turn OFF. Seek support
Signal out of range	Check analogue control signal range. Trim signal as required. Or seek support
Over signal	Reduce the analogue control signal
No signal	Connect analogue control signal or return to manual control
Leak detected. Check and reset	Remove the cause of any leak. The STOP key resets
Unrecognised key-press	Attempt key-press again. Attempt to reset by switching power OFF/ON. Or seek support
Work overload	Turn OFF. Check power supply. Check pumphead and tubing. Wait 30 minutes. Power ON may reset. Or seek support
Network not detected	Turn OFF. Check network and connections. Or seek support
RS485 fault	Turn OFF. Check network and connections. Or seek support
RS485 lost	Turn OFF. Check network and connections. Or seek support
General error condition	Turn OFF. Seek support

26 Drive maintenance

There are no user serviceable parts inside the pump (except the power cable: see 10 *Connecting this product to a power supply*). The unit should be returned to Watson-Marlow or its appointed agents or distributors for service.

27 Drive spares

Replaceable main fuse, type T2,5A H 250V 20mm: FS0064	Foot: MN2507M
Module seal: MN2507M	
Module pcb: MNA2066A	Module switch cover: MN2505M
Glands: GR0056	Blanking plugs: GR0057
Sealing washer for blanking plug and gland: GR0058	Snap-fit vent: MN2513B

28 The 520R, 520R2 and 520RE pumpheads

Identification of parts



520R/520R2		520REL/520REM/520REH	
1	Guard latch	5	Rotor cap
2	Guard (520R, 520R2)	6	Tube guide roller
3	Track	7	Rotor
4	Clutch button cover	8	Follower roller
		9	Pumping roller
		10	Tube clamp slider (520R, 520R2)
		11	Tube clamp (520R, 520R2)
		12	Guard with seal (520RE)
		13	Drain port (520RE)

28.1 Pumphead position, removal and replacement



Always isolate the pump from the mains power supply before opening the guard or performing any positioning, removal or maintenance activity.

The pumphead track can be fitted in one of three orientations to provide right, up or down input/output port positions, whichever is convenient. Position the pumphead so that the tube ports face up or down only where the drive is placed on the bench edge - otherwise the pump tube or the hinged guard will impact the bench. Do not position the pumphead so that the tube ports face the keypad. Doing so may result in a safety risk.

The pump can be configured for clockwise or counter-clockwise rotor rotation. Please note, however, that tube life will be greater if the rotor rotates clockwise; and that performance against pressure will be maximized if the rotor rotates counter-clockwise.

To reposition the track

- Open the pumphead guard as described under 27.1 *Opening the pumphead guard*, below.
- Remove the rotor as described under *Rotor removal*, below.



- Undo and withdraw the four track-retaining screws using a slotted screwdriver.
- Remove the track.
- Relocate the track in the desired position. Replace and tighten the track-retaining screws.
- Replace the rotor as described under *Rotor replacement* below.
- Close the guard, pushing it fully home until the latch engages.

Rotor removal

- Remove any tubing from the pumphead.

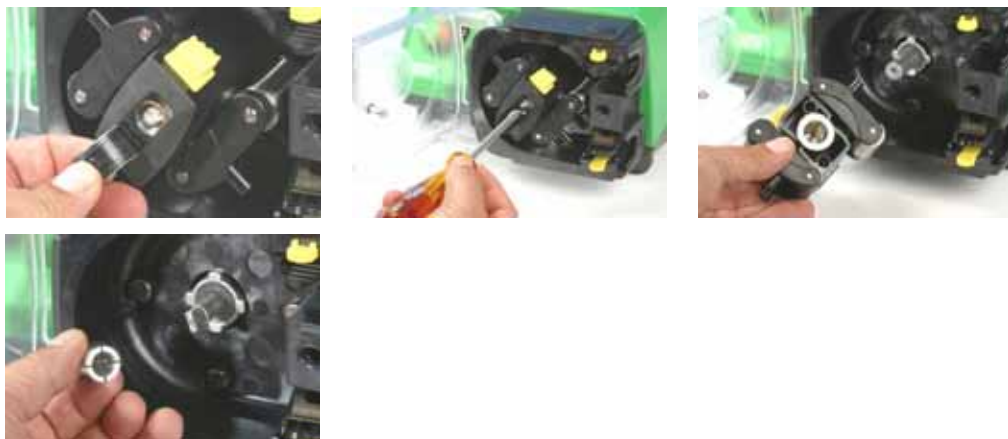

- Open the flexible rotor cap in the centre of the rotor.
- Undo and withdraw the central locating screw using a slotted screwdriver.
- Pull the rotor hub off its dogged shaft.
- Between the hub and the shaft is a split collet. If the collet is retained by the shaft, pull it off, loosening it if necessary by tapping it lightly. Avoid levering it off using a screwdriver or other tool. If the collet is retained within the hub, remove it, loosening it if necessary by reinserting the central locating screw a turn or two and tapping the screw head lightly.

Rotor replacement



- Re-locate the split collet onto the drive shaft, rotating it until it fully engages the dog. Fit the rotor body over the drive shaft.
- Open the flexible rotor cap in the centre of the rotor. Use a slotted screwdriver to tighten the central locating screw to a torque of 3Nm (2.2 lb-ft) to prevent collet slip during operation. When fitted correctly, the tube guide rollers should align with the outer face of the track. Close the flexible rotor cap.
- Close the guard and ensure that the rotor is clear of the guard by observing the first few rotor rotations.

29 520R, 520R2 and 520RE commissioning



Always isolate the pump from the mains power supply before opening the guard or performing any positioning, removal or maintenance activity.

29.1 Opening the pumphead guard

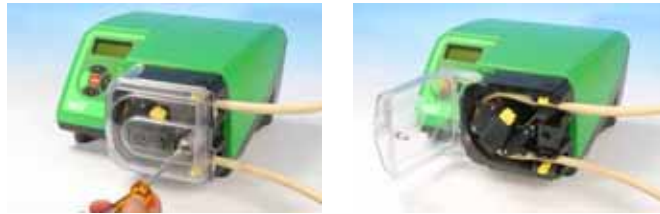

- Unlock the pumphead guard by turning the guard fastener $\frac{1}{4}$ turn anticlockwise with a slotted screwdriver.
- Open the guard to its full extent to create maximum clearance for the tube ports.
- Ensure that the rollers rotate freely and that the tube clamps are clean.

29.2 520R and 520R2 tube loading

520R continuous tubing pumpheads are factory-set to accept Watson-Marlow 1.6mm-wall tubing. 520R2 continuous tubing pumpheads are factory set to accept Watson-Marlow 2.4mm-wall tubing. Pumping performance may be adversely affected if Watson-Marlow tubing is not used.

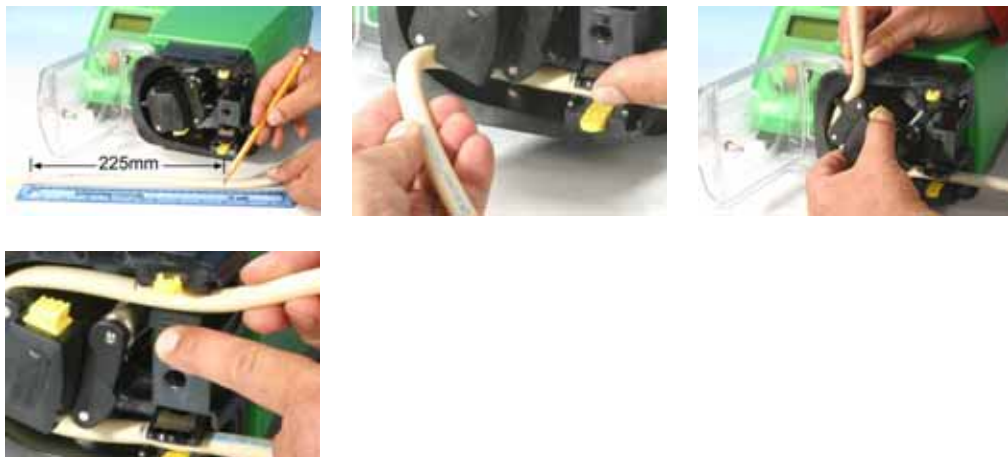

- Mark a 225mm (8 ⁷/₈ in) length onto the section of the tubing which is to be located into the pumphead. **Caution:** Placing more than 225mm (8 ⁷/₈ in) of tube inside the pumphead may result in reduced tube life.
- Open the lower spring-loaded tube clamp and locate the tubing, with the first 225mm (8 ⁷/₈ in) length mark aligned to the inside face of the spring-loaded part of the tube clamp. Release the clamp.
- Disengage the rotor clutch by fully depressing the yellow clutch button on the side of the rotor hub and turning the hub a few degrees while the clutch button is still depressed. The rotor can now rotate independently of the gearbox and motor for one full revolution. If the clutch re-engages before tube fitting is complete, depress the clutch button again and turn the rotor a few degrees.
- Feed the tubing around the pumphead track, turning the rotor as necessary. Make sure the tubing is not twisted or pinched between the guide rollers and the track. Ensure that the second 225mm (8 ⁷/₈ in) mark is adjacent to the inner edge of the upper tube clamp.
- Open the upper spring-loaded tube clamp and locate the tubing into it, making sure there is no residual twist in the tubing, and that the tube sits centrally between the tube guide rollers. Release the clamp.



- The spring-loaded tube clamps must grip the tubing tightly enough to stop it moving in and out of the pumphead but must not over-squeeze the tube and throttle fluid flow. The tubing clamps are fitted with yellow sliders which can be clicked into two positions while the clamps are held open: the outer position will allow the clamps to grip the tube tightly; the inner will grip the tube loosely. Adjust the sliders to prevent tube movement during a few trial rotations of the rotor.
- Close the guard, pushing it fully home until the latch engages.
- Connect suitable pipework to the pumphead tubing using appropriate connectors.
- Remember, when using Marprene or Bioprene tubing, re-tension the tubing after 30 minutes of running, as it may grow in length as it beds in. Re-tension so that 225mm (8 7/8 in) of tubing sits between the inside faces of the spring-loaded parts of the tube clamps.

29.3 520RE: fitting the drain port

The drain port is an optional extra, supplied with the pumphead. It is strongly recommended that users fit it before the pump is operated. It may be done with the rotor in position or removed.





- Remove the drain plug from the bottom of the pumphead. The drain plug is flexible. It may be removed using finger pressure from within the pumphead, or by accessing its flange from outside with a fingernail.
- Drop the port into position from inside the pumphead.
- Fit the supplied port retaining nut (3/8 in BSP) and finger-tighten.
- Fit drainage pipework as required (not supplied).

29.4 520RE Element loading

520RE tubing element pumpheads are factory-set to accept Watson-Marlow 2.4mm-wall tubing elements. Elements fitted with either quick-release industrial connectors or Tri-clamp sanitary connectors may be used; however, **it is vital to match the pressure rating of the element with the pressure rating of the pumphead** so that the correct roller-spring rate and occlusion settings are used. The pressure rating of the pumphead appears on the flexible rotor cap in the centre of the rotor. The pressure rating of the element appears on the connector sleeve.

Note that the rotor cap and the element connector sleeve are colour-coded.

Note: To achieve 4 bar and 7 bar pressures using a 520RE pump and the appropriate rotor and element, the pump **must** rotate counter-clockwise.

Element and rotor pressure ratings					
Colour of flexible rotor cap and element connector sleeve					
Grey		Beige		Blue	
					
520REL Pressures up to 2 bar (30 psi) Bore sizes 3.2mm, 6.4mm and 9.6mm		520REM Pressures up to 4 bar (60 psi) Bore sizes 3.2mm and 6.4mm		520REH Pressures up to 7 bar (100 psi) Bore size 3.2mm	
Industrial Marprene TL Pumpsil Neoprene Chem-Sure	Sanitary Bioprene TL Pumpsil Sta-Pure Chem-Sure	Industrial Marprene TM Chem-Sure	Sanitary Bioprene TM Sta-Pure	Industrial Marprene TH Sta-Pure	Sanitary Bioprene TH Sta-Pure

Element connectors for industrial and sanitary use	
Industrial	Sanitary
	



Check that the conical connector sleeve of the element to be fitted is the same colour as the pumphead rotor cap

520RE element loading procedure

Note: The element loading procedure is the same for industrial (pictured) and sanitary elements.



- Select an appropriate Watson-Marlow 520RE tubing element, paying attention to pressure capability, bore size, tubing material and type of connector. See the table above for pressure ratings. **Check that the connector sleeve of the element to be fitted is the same colour as the pumphead rotor cap.**
- Slide the connector D-flange at one end of the element into the lower connector D-slot.
- Disengage the rotor clutch by fully depressing the yellow clutch button on the side of the rotor hub and turning the hub a few degrees while the clutch button is still depressed. The rotor can now rotate independently of the gearbox and motor for one full revolution. If the clutch re-engages before tube fitting is complete, depress the clutch button again and turn the rotor a few degrees.
- Feed the tubing element around the pumphead track, turning the rotor as necessary. Make sure the tubing is not twisted or pinched between the guide rollers and the track.
- Slide the second connector D-flange into the upper connector D-slot.
- Check that the element lies in the middle of the track and that the connector flanges are pushed fully home.
- Close the guard, pushing it fully home until the latch engages.
- Connect suitable pipework to the pumphead tubing using appropriate connectors. See below.

29.5 520RE Element connection

Select suitable tubing to connect to the tubing element supply and discharge connectors. Check that its pressure rating is appropriate to the application.

Sanitary $\frac{3}{4}$ in mini-Tri-clamp connectors

Sanitary connectors are connected to a tubing system using mini-Tri-clamps and gaskets.



- Hold the connector end of the supply or discharge tube against the element connector, with a gasket between them.
- Use a Tri-clamp to engage both flanges squarely, close it and tighten.

Industrial quick-release connectors

Industrial connectors are connected to a tubing system using quick-release fittings.



- Hold the pump securely and push the female fitting (available from Watson-Marlow Bredel) over the element until it clicks into place.



- To disconnect, hold the pump securely and pull the connector outer sleeve and twist counter-clockwise while pulling the female connector away.

30 520R, 520R2 and 520RE maintenance



Always isolate the pump from the mains power supply before opening the guard or performing any positioning, removal or maintenance activity.

- As part of regular cleaning and maintenance (and at least every three months), lubricate the pivot points, the follower rollers and the tube guide rollers with Ultra Lube (PA 1240), which is a non-toxic perfluoroether-based grease.
- The stainless steel pumping rollers run on externally-sealed bearings and are lubricated for life.
- Check that the pumphead track, rotor, rollers and spring-loaded tube clamps (if fitted) are clean and operating properly.
- If fluid is spilled inside the pumphead it should be cleaned as soon as possible, as reducing exposure time to contamination will prolong pumphead service life.
- To clean the pumphead, remove the rotor as described under *Rotor removal*, above. Flush the pumphead out with water and mild detergent, or suitable cleaning agent. Clean the rotor and rollers in the same way. If specific cleaning agents are required to clean the spillage, consult the general guide to cleaning with solvents below or Watson-Marlow after-sales office before proceeding, in order to confirm chemical compatibility. **Note:** the pumphead guard, rotor cap and clutch boot should be removed in advance of some cleaning regimes. See the table below. These components are available as spares if damaged.
- Replace the rotor as described under *Rotor replacement*, above.

General guide to cleaning with solvents

Chemical	Cleaning precautions
Aliphatic hydrocarbons	Remove guard. Minimize rotor cap and clutch boot exposure to less than one minute (risk of attack). Re-lubricate follower and tube guide rollers.
Aromatic hydrocarbons	Remove guard. Minimize rotor cap and clutch boot exposure to less than one minute (risk of attack). Re-lubricate follower and tube guide rollers.
Ketone solvents	Remove guard. Minimize rotor cap and clutch boot exposure to less than one minute (risk of attack). Re-lubricate follower and tube guide rollers.
Halogenated/chlorinated solvents	Not recommended: possible risk to polycarbonate tube clamp adjusters and polypropylene tube clamp locators.
Alcohols, general	No precaution necessary. Re-lubricate follower and tube guide rollers.
Glycols	Minimize rotor cap and clutch boot exposure to less than one minute (risk of attack). Re-lubricate follower and tube guide rollers.
Ester solvents	Remove guard. Minimize rotor cap and tube clamp location cap exposure to less than one minute (risk of attack). Re-lubricate follower and tube guide rollers.
Ether solvents	Not recommended: possible risk to polycarbonate tube clamp adjusters and polypropylene tube clamp locators.

31 520R, 520R2 and 520RE rotor settings

520R, 520R2 and 520RE pumpheads are factory-set to give optimum tube life with Watson-Marlow tubing and elements. Radial roller positions should not be adjusted in any circumstances as this will adversely affect pumphead performance and invalidate warranty. Tamper-proof rotor arm occlusion setting screws are fitted to warn operators from occlusion adjustment. Tubing with a wall thickness other than 1.6mm or 2.4mm can be used only with a pumphead set up for that purpose during manufacture. Contact Watson-Marlow after-sales.

32 Pumphead spares



520R/520R2	520REL/520REM/520REH
053.1011.100	520R
053.1011.2L0	520R2
053.1011.EL0	520REL
053.1011.EM0	520REM
053.1011.EH0	520REH
1 MNA2050A (520R, 520R2)	Pumphead guard complete with tool-unlockable latch
2 MNA2045A (520R, 520R2)	Track assembly for cased pumps complete with spring-loaded tube clamps
3 MNA2076A (520R - 1.6mm wall tube) MNA2077A (520R2 - 2.4mm wall tube) MNA2148A (grey) (520REL) MNA2149A (beige) (520REM) MNA2150A (blue) (520REH)	Rotor cover, rotor cap and clutch button
4 MN2011M S60022	Clutch Clutch spring
5 MNA2043A (520R - 1.6mm wall tube) MNA2001A (520R2 - 2.4mm wall tube) MNA2138A (520REL - 0-2 bar, 0-30 psi) MNA2139A (520REM - 2-4 bar, 30-60 psi) MNA2140A (520REH - 4-7 bar, 60-100 psi)	Rotor assembly complete with pumping rollers, follower rollers and tube guide rollers
6 MNA2006A (520R, 520R2) MN2002M (520R, 520R2) MN2131M (520RE)	Bottom (LH) tube clamp Tube clamp location plug Drain plug
7 MNA2005A (520R, 520R2) MN2002M (520R, 520R2)	Top (RH) tube clamp Tube clamp location plug
8 MN2034B MN2005M	Guard latch spring Guard latch spring cartridge
9 MNA2147A (520RE)	Pumphead guard complete with seal and tool-unlockable latch
10 MNA2144A (520RE)	Track assembly for cased pumps
11 MN2023T and MN2003T (520RE)	Drain port and nut

Parts may be ordered individually.

33 Flow rates

Pumping conditions

For precise and repeatable performance it is important to determine flow rates under operating conditions for each new piece of tubing.

When rotating counter-clockwise, 520R, 520R2 and 520RE pumpheads' flow rates are directly proportional to rotor speed. When rotating clockwise, 520R, 520R2 and 520RE pumpheads' flow rates are directly proportional to rotor speed up to 1.5 bar; their performance above 1.5 bar should be determined empirically.

Note: 520RE pumpheads should be used rotating counter-clockwise if pressures above 1.5 bar are required.

If you wish to run the pump at a speed not shown in the tables below, flow figures can be reached by dividing the maximum flow shown in the tables below by the maximum rpm figure, and multiplying the result by your required speed in rpm.

Actual flow rates achieved may vary because of changes in temperature, viscosity, inlet and discharge pressures, system configuration and tubing performance against time. Flow rates may also vary due to normal manufacturing tolerances of the tubing. These tolerances will make flow rate variance more pronounced at smaller bore sizes.

520R and 520R2

All performance figures for the 520R and 520R2 pumpheads have been recorded against peak pipeline pressures.

Although rated to 2 bar (30psi) peak pressure, this pump will generate in excess of 2 bar (30psi) peak pressure if the pipeline is restricted. Where it is important that 2 bar (30psi) is not exceeded, pressure relief valves should be installed in the pipeline.

Viscosity handling is maximised by using 2.4mm wall tubing with the 520R2 pumphead.

Flow rates are normalised test values obtained using 225mm (8 7/8 in) of new tubing (measured from the inside faces of the tube clamps), and the pumphead rotating clockwise pumping water at 20C with negligible inlet and discharge pressures.

Note: Flow rates quoted are for 1.6mm and 2.4mm wall tubes. Tubes of 0.5mm and 0.8mm bore are only available in 1.6mm wall thickness except for platinum-cured silicone. Tubes of 9.6mm bore are only available in 2.4mm wall thickness.

520RE

Performance figures for the 520REL and 520REM have been recorded against 2 bar peak pressure and 4 bar peak pressure respectively.

Performance figures for the 520REH have been recorded against 7 bar constant pressure.

Although the 520REL is rated to 2 bar (30psi) peak pressure, the 520REM is rated to 4 bar (60psi) peak pressure and the 520REH is rated to 7 bar (100psi) constant pressure, the pumps will generate in excess of these pressures if the system pressures exceed this. Where it is important that these rated pressures are not exceeded, pressure relief valves should be installed in the pipeline.

Flow rates are normalised test values obtained using 520 elements and the pump-head rotating anticlockwise pumping water at 20C with negligible inlet and discharge pressures.

Tube life

Application factors that influence tube life in peristaltic pumps are pump speed and number of rollers (roller impacts/minute), chemical compatibility and viscosity of the duty fluid and suction and discharge pressure. Several tubing materials are available with different levels of life expectancy. In addition, tubing's dimensional tolerances from the manufacturing process affect its life.

In perfect conditions of no suction or discharge pressure, pumping water in a clean environment at normal room temperature, the following nominal tube life may be experienced:

	520R and 520R2
Marprene, Bioprene, STA-PURE PCS and STA-PURE PFL	less than 10,000 hours
Silicone	less than 250 hours
Others	less than 100 hours

Note: This is a guide only. It is not possible to make an accurate assessment of tube life except by trial of a real application.

Continuous tubing

520R Neoprene, STA-PURE PCS, STA-PURE PFL, PVC, Pumpsil (ml/min)								
Speed range	0.5mm	0.8mm	1.6mm	3.2mm	4.8mm	6.4mm	8.0mm	9.6mm
520DuN/R, 520DuN/R2								
0.1-220rpm	0.004-9.5	0.01-24	0.04-97	0.18-390	0.40-870	0.70-1500	1.1-2400	1.6-3500

520R Marprene / Bioprene 64 shore tubing (ml/min)								
Speed range	0.5mm	0.8mm	1.6mm	3.2mm	4.8mm	6.4mm	8.0mm	9.6mm
520DuN/R, 520DuN/R2								
0.1-220rpm	0.004-9.0	0.01-23	0.04-92	0.17-370	0.38-830	0.67-1500	1.1-2300	1.5-3300

520R Fluorel (ml/min)					
Speed range	1.6mm	3.2mm	4.8mm	6.4mm	8.0mm
520DuN/R, 520DuN/R2					
0.1-220rpm	0.03-70	0.13-280	0.29-630	0.51-1100	0.80-1800

520R Neoprene, STA-PURE PCS, STA-PURE PFL, PVC, Pumpsil (USGPH)								
Speed range	0.5mm	0.8mm	1.6mm	3.2mm	4.8mm	6.4mm	8.0mm	9.6mm
520DuN/R, 520DuN/R2								
0.1-220rpm	0.0001-0.14	0.0002-0.35	0.001-1.4	0.003-5.6	0.006-13	0.01-22	0.02-35	0.03-50

520R Marprene / Bioprene 64 shore tubing (USGPH)								
Speed range	0.5mm	0.8mm	1.6mm	3.2mm	4.8mm	6.4mm	8.0mm	9.6mm
520DuN/R, 520DuN/R2								
0.1-220rpm	0.0001-0.14	0.0002-0.37	0.001-1.5	0.003-5.9	0.01-13	0.01-23	0.02-37	0.02-53

520R Fluorel (USGPH)					
Speed range	1.6mm	3.2mm	4.8mm	6.4mm	8.0mm
520DuN/R, 520DuN/R2					
0.1-220rpm	0.0005-1.1	0.002-4.5	0.005-10	0.01-18	0.01-28

Elements

520REL Neoprene, STA-PURE PCS, STA-PURE PFL, Pumpsil (ml/min)				520REL Marprene / Bioprene TL (ml/min)		
Speed range	3.2mm	6.4mm	9.6mm	3.2mm	6.4mm	9.6mm
520DuN/REL						
0.1-220rpm	0.18-390	0.70-1500	1.6-3500	0.17-370	0.67-1500	1.5-3300

520REL Neoprene, STA-PURE PCS, STA-PURE PFL, Pumpsil (USGPH)				520REL Marprene / Bioprene TL (USGPH)		
Speed range	3.2mm	6.4mm	9.6mm	3.2mm	6.4mm	9.6mm
520DuN/REL						
0.1-220rpm	0.003-6.1	0.01-25	0.03-55	0.003-5.9	0.01-23	0.02-53

520REM STA-PURE PCS, STA-PURE PFL (ml/min)			520REM Marprene / Bioprene TM (ml/min)	
Speed range	3.2mm	6.4mm	3.2mm	6.4mm
520DuN/REM				
0.1-220rpm	0.18-390	0.70-1500	0.17-370	0.67-1500

520REM STA-PURE PCS, STA-PURE PFL (USGPH)		520REM Marprene / Bioprene TM (USGPH)		
Speed range	3.2mm	6.4mm	3.2mm	6.4mm
520DuN/REM				
0.1-220rpm	0.003-6.1	0.01-25	0.003-5.9	0.01-23

520REH Marprene / Bioprene TH, STA-PURE PCS (ml/min)		520REH Marprene / Bioprene TH, STA-PURE PCS (USGPH)	
Speed range	3.2mm		3.2mm
520DuN/REH			
0.1-220rpm	0.20-450		0.003-7.1

Performance curves

Marprene continuous tubing, 1.6mm wall, 200rpm, clockwise rotation

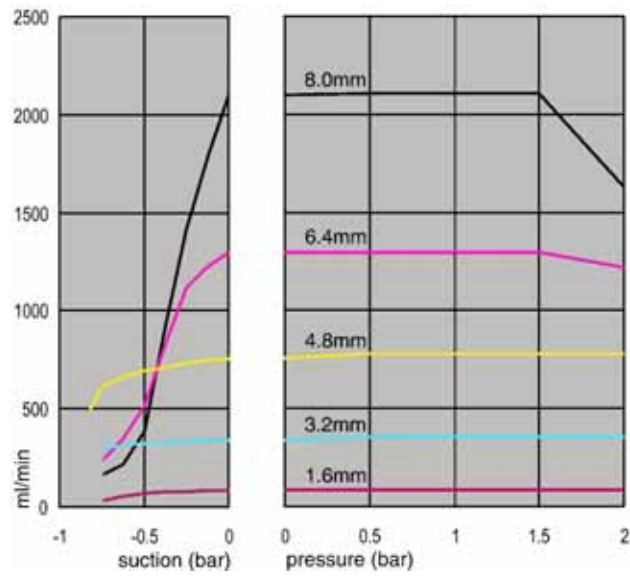

Marprene continuous tubing, 1.6mm wall, 200rpm, counter-clockwise rotation

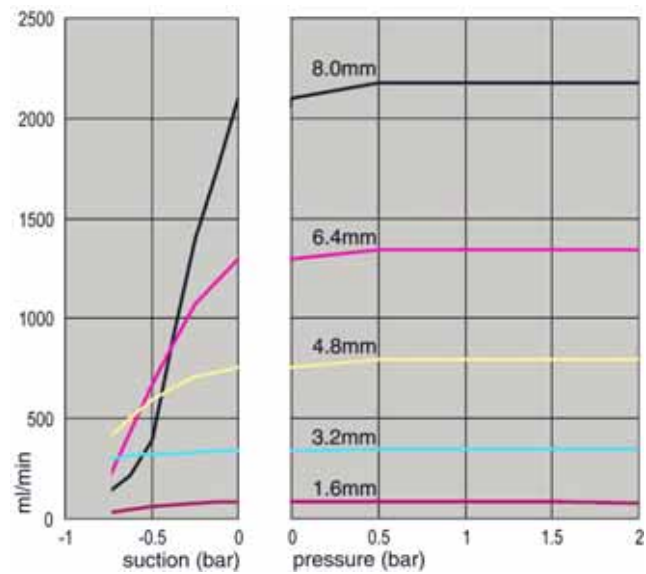

Marprene continuous tubing, 2.4mm wall, 200rpm, clockwise rotation

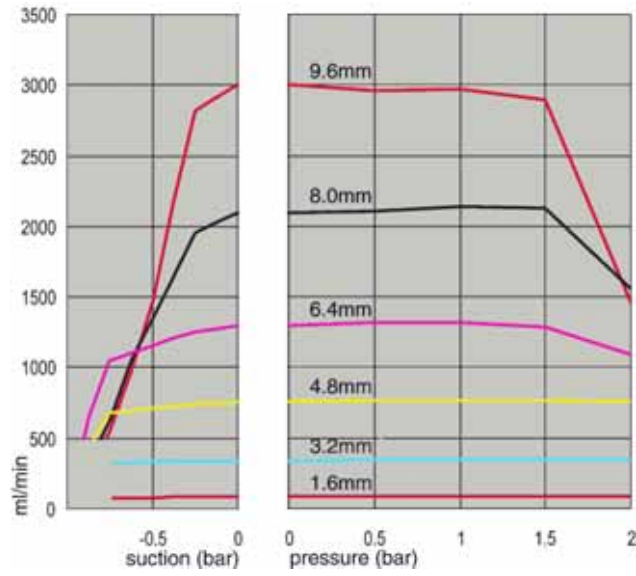

Marprene continuous tubing, 2.4mm wall, 200rpm, counter-clockwise rotation

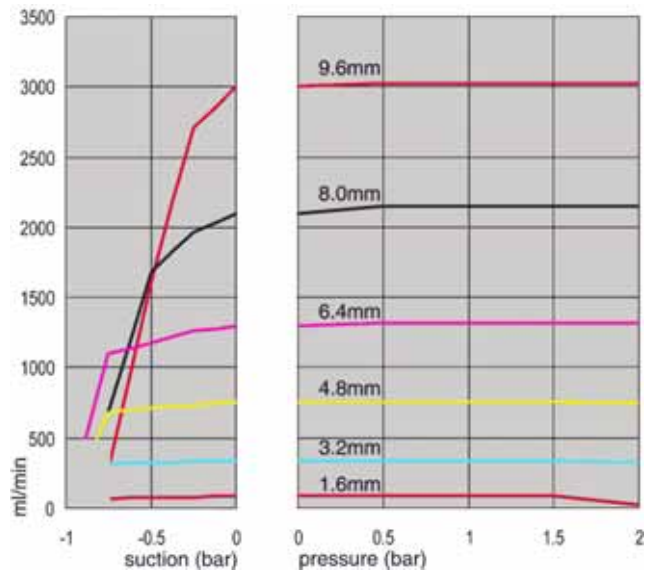

Marprene TL element, 0-2 bar (0-30psi), 200rpm, counter-clockwise rotation

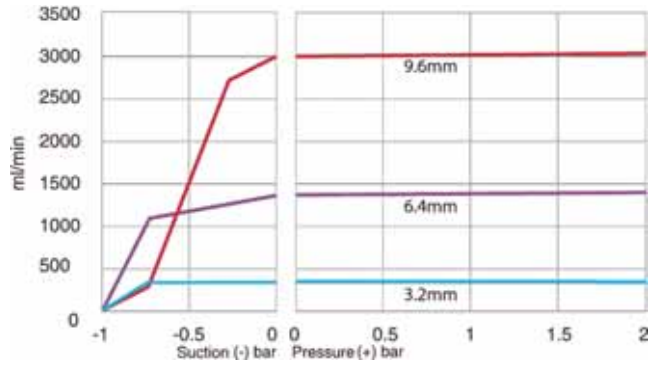

Sta-Pure element, 0-2 bar (0-30psi), 200rpm, counter-clockwise rotation

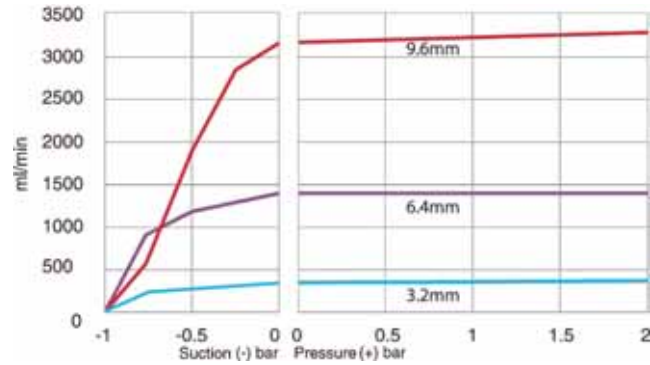

Marprene TM element, 2-4 bar (30-60psi), 200rpm, counter-clockwise rotation

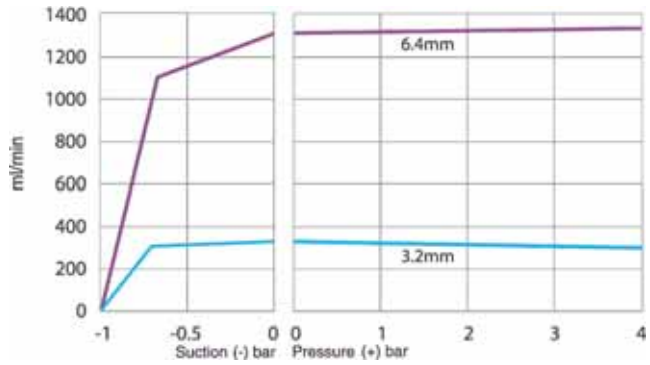

Sta-Pure element, 2-4 bar (30-60psi), 200rpm, counter-clockwise rotation

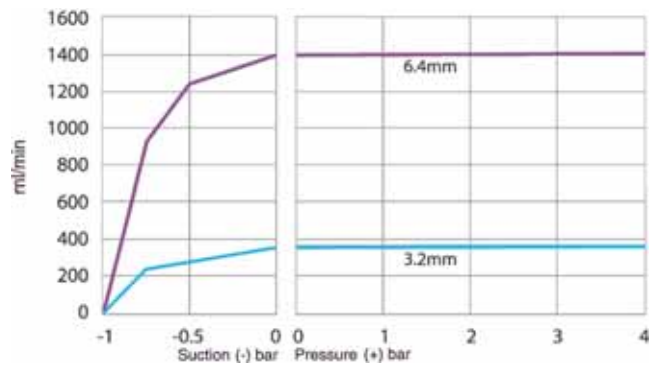

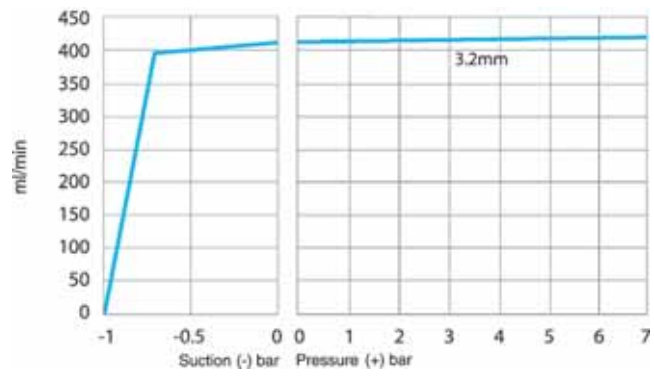

Marprene TH element, 4-7 bar (60-100psi), 200rpm, counter-clockwise rotation





34 Tubing and element part numbers

1.6mm wall tubing for 520R pumpheads

					
mm	inch	#	Marprene	Bioprene	STA-PURE PFL
0.5	1/50	112	902.0005.016	903.0005.016	
0.8	1/32	13	902.0008.016	903.0008.016	
1.6	1/16	14	902.0016.016	903.0016.016	965.0016.016
3.2	1/8	16	902.0032.016	903.0032.016	965.0032.016
4.8	3/16	25	902.0048.016	903.0048.016	965.0048.016
6.4	1/4	17	902.0064.016	903.0064.016	965.0064.016
8.0	5/16	18	902.0080.016	903.0080.016	965.0080.016
mm	inch	#	PVC	Fluorel	Neoprene
0.8	1/32	13			920.0008.016
1.6	1/16	14	950.0016.016	970.0016.016	920.0016.016
3.2	1/8	16	950.0032.016	970.0032.016	920.0032.016
4.8	3/16	25	950.0048.016	970.0048.016	920.0048.016
6.4	1/4	17	950.0064.016	970.0064.016	920.0064.016
8.0	5/16	18	950.0080.016	970.0080.016	920.0080.016
mm	inch	#	Pumpsil	STA-PURE PCS	
0.5	1/50	112	913.A005.016		
0.8	1/32	13	913.A008.016		
1.6	1/16	14	913.A016.016	960.0016.016	
3.2	1/8	16	913.A032.016	960.0032.016	
4.8	3/16	25	913.A048.016	960.0048.016	
6.4	1/4	17	913.A064.016	960.0064.016	
8.0	5/16	18	913.A080.016	960.0080.016	

Note: 1.6mm wall STA-PURE PCS and STA-PURE PFL tubing are supplied in 305mm lengths.

2.4mm wall tubing for 520R2 pumpheads

					
mm	inch	#	Marprene	Bioprene	Pumpsil
0.5	1/50				913.A005.024
0.8	1/32				913.A008.024
1.6	1/16	119	902.0016.024	903.0016.024	913.A016.024
3.2	1/8	120	902.0032.024	903.0032.024	913.A032.024
4.8	3/16	15	902.0048.024	903.0048.024	913.A048.024
6.4	1/4	24	902.0064.024	903.0064.024	913.A064.024
8.0	5/16	121	902.0080.024	903.0080.024	913.A080.024
9.6	3/8	122	902.0096.024	903.0096.024	913.A096.024
mm	inch	#	STA-PURE PFL	STA-PURE PCS	
1.6	1/16	119	965.0016.024	960.0016.024	
3.2	1/8	120	965.0032.024	960.0032.024	
4.8	3/16	15	965.0048.024	960.0048.024	
6.4	1/4	24	965.0064.024	960.0064.024	
8.0	5/16	121	965.0080.024	960.0080.024	

Note: 2.4mm wall STA-PURE PCS and STA-PURE PFL tubing are supplied in 355mm lengths.

2.4mm wall elements for 520RE pumpheads

0-2 bar (0-30 psi) pressure rated elements



Industrial

mm	inch	#	Marprene TL	Pumpsil	Neoprene	STA-PURE PFL
3.2	1/8	16	902.0032.PFQ	913.A032.PFQ	920.0032.PFQ	965.0032.PFQ
6.4	1/4	17	902.0064.PFQ	913.A064.PFQ	920.0064.PFQ	965.0064.PFQ
9.6	3/8	122	902.0096.PFQ	913.A096.PFQ	920.0096.PFQ	965.0096.PFQ

Sanitary

mm	inch	#	Bioprene TL	Pumpsil	STA-PURE PCS	STA-PURE PFL
3.2	1/8	16	903.0032.PFT	913.A032.PFT	960.0032.PFT	965.0032.PFT
6.4	1/4	17	903.0064.PFT	913.A064.PFT	960.0064.PFT	965.0064.PFT
9.6	3/8	122	903.0096.PFT	913.A096.PFT	960.0096.PFT	965.0096.PFT

2-4 bar (30-60 psi) pressure rated elements



Industrial

mm	inch	#	Marprene TM	STA-PURE PFL
3.2	1/8	16	902.P032.PFQ	965.M032.PFQ
6.4	1/4	17	902.P064.PFQ	965.M064.PFQ

Sanitary

mm	inch	#	Bioprene TM	STA-PURE PCS
3.2	1/8	16	903.P032.PFT	960.M032.PFT
6.4	1/4	17	903.P064.PFT	960.M064.PFT

4-7 bar (60-100 psi) pressure rated elements



Industrial

mm	inch	#	Marprene TM	STA-PURE PCS
3.2	1/8	16	902.H032.PFQ	960.H032.PFQ

Sanitary

mm	inch	#	Bioprene TM	STA-PURE PCS
3.2	1/8	16	903.H032.PFT	960.H032.PFT

35 520 series pumping accessories

Accessory	Description	Part code	Pump compatibility
520ANC	Network cable, RS232, with 9-pin D-connectors	059.3121.000	520Du, 520Di
520ANX	Network extension cable with 9-pin D-connectors	059.3122.000	520Du, 520Di
520ANA	Network adaptor, 25-pin to 9-pin D-connectors	059.3123.000	
520AB	Batch records cable with 9-pin D-connectors	059.3125.000	520Di
520AF	Footswitch with 25-pin D-connector	059.3002.000	520U, 520Du, 520Di
520AH	Handswitch with 25-pin D-connector	059.3022.000	520U, 520Du, 520Di
520AV	Proximity switch	059.5072.000	520Di
520AVN	Proximity switch	059.507N.000	520DiN
505LTC	Tube clamp set for 505L pumphead	059.4001.000	520Di
505AS	Filling stand	059.5001.000	All models
520AL	Dispensing lance for use with 520AFN filling needles	059.5052.000	All models
505AFN	Filling needle set	059.5101.000	All models
	Filling needle 1.6mm bore	059.5100.016	All models
	Filling needle 3.2mm bore	059.5100.032	All models
	Filling needle 4.8mm bore	059.5100.048	All models
	Filling needle 6.4mm bore	059.5100.064	All models
	Filling needle 8.0mm bore	059.5100.080	All models
	Tube monitor with 25-pin D-connector	059.4501.520	520U, 520Du, 520Di
	Tube monitor, bare lead	059.450N.520	520UN, 520DuN, 520DiN
520AD	Leak detector kit	059.8121.000	520U, 520Du, 520Di
520AD	Leak detector kit	059.8131.000	520UN, 520DuN, 520DiN

36 Trademarks

Watson-Marlow, Bioprene, Pumpsil, LoadSure and **Marprene** are trademarks of Watson-Marlow Limited.

Fuorel is a trademark of 3M.

STA-PURE PCS and **STA-PURE PFL** are trademarks of W.L.Gore and Associates.

37 Warning not to use pumps in patient-connected applications

Warning These products are not designed for use in, and should not be used for patient-connected applications.

38 Publication history

m-520dus-4x-us-05.qxp: Watson-Marlow 520DuS IP66 NEMA 4X

First published 12 03. Revised 09 06. Revised 01 08. Revised 11 10.

39 Decontamination certificate

In compliance with the *UK Health and Safety at Work Act* and the *Control of Substances Hazardous to Health Regulations*, you are required to declare the substances which have been in contact with product(s) you return to Watson-Marlow or its subsidiaries or distributors. Failure to do so will cause delays. Please ensure that you fax us this form and receive an RGA (Returned Goods Authorisation) before you despatch the product(s). A copy of this form must be attached to the outside of the packaging containing the product(s). Please complete a separate decontamination certificate for each product.

You are responsible for cleaning and decontaminating the product(s) before return.

Your name	<input type="text"/>	Company	<input type="text"/>
Address	<input type="text"/>		
Postcode/zip	<input type="text"/>	Country	<input type="text"/>
Telephone	<input type="text"/>	Fax	<input type="text"/>
Product type	<input type="text"/>	Serial number	<input type="text"/>
To speed the repair, please describe all known faults	<input type="text"/>		
The product has ...	<input type="checkbox"/> Been used <input type="checkbox"/> Not been used		
	<i>If the product has been used, please complete all the following sections. If the product has not been used, please just sign this form.</i>		
Names of chemicals handled with product(s)	<input type="text"/>		
Precautions to be taken in handling these chemicals	<input type="text"/>		
Action to be taken in the event of human contact	<input type="text"/>		
	<i>I understand that the personal data collected will be kept confidentially in accordance with the UK Data Protection Act 1998.</i>		
Signature	<input type="text"/>	RGA number	<input type="text"/>
		Your position	<input type="text"/>
		Date	<input type="text"/>
	<i>Please print out, sign and fax to Watson-Marlow Pumps at +44 1326 376009.</i>		