

This manual is to be given to
the end user

VARMECA 30

Variable speed motor or geared motor

Installation and maintenance

VARMECA 30

Variable speed motor or geared motor

NOTE

LEROY-SOMER reserves the right to modify the characteristics of its products at any time in order to incorporate the latest technological developments. The information contained in this document may therefore be changed without notice.



For the user's own safety, this VARMECA 30 motor must be connected to an approved earth (⊕ terminal). If accidentally starting the installation is likely to cause a risk to personnel or the machines being driven, it is essential to supply the equipment via a circuit-breaking device (power contactor) which can be controlled via an external safety system (emergency stop, detection of errors on the installation).

The VARMECA 30 motor is fitted with safety devices which, in the event of a fault, control stopping and thus stop the motor. The motor itself can become jammed for mechanical reasons. Voltage fluctuations, and in particular power cuts, may also cause the motor to stop.

The removal of the causes of the shutdown can lead to restarting, which may be dangerous for certain machines or installations. In such cases, it is essential that the user takes appropriate precautions against the motor restarting after an unscheduled stop. The variable speed drive is designed to be able to supply a motor and the driven machine above its rated speed.

If the motor or the machine are not mechanically designed to withstand such speeds, the user may be exposed to serious danger resulting from their mechanical deterioration. It is important that the user checks that the installation can withstand it, before programming a high speed.

The variable speed drive which is the subject of this manual is designed to be integrated in an installation or an electrical machine, and can under no circumstances be considered to be a safety device. It is therefore the responsibility of the machine manufacturer, the designer of the installation or the user to take all necessary precautions to ensure that the system complies with current standards, and to provide any devices required to ensure the safety of equipment and personnel.

LEROY-SOMER declines all responsibility in the event of the above recommendations not being observed.

VARMECA 30

Variable speed motor or geared motor

SAFETY AND OPERATING INSTRUCTIONS FOR ELECTRICAL ACTUATORS (In accordance with the low voltage directive 73/23/EEC modified by 93/68/EEC)

 • Throughout the manual, this symbol warns of consequences which may arise from inappropriate use of the VARMECA 30, since electrical risks may lead to material or physical damage as well as constituting a fire hazard.

1 - General

Depending on their degree of protection, VARMECA 30 motors may contain moving parts, as well as hot surfaces, during operation.

Unjustified removal of protection devices, incorrect use, faulty installation or inappropriate operation could represent a serious risk to personnel and equipment.

For further information, consult the manual.

All work relating to transportation, installation, commissioning and maintenance must be performed by experienced, qualified personnel (see IEC 364 or CENELEC HD 384, or DIN VDE 0100 and national specifications for installation and accident prevention).

In these basic safety instructions, qualified personnel means persons competent to install, mount, commission and operate the product and possessing the relevant qualifications.

2 - Use

VARMECA 30 motors are components designed for integration in installations or electrical machines.

When integrated in a machine, commissioning must not take place until it has been verified that the machine conforms with directive 89/392/EEC (Machinery Directive).

It is also necessary to comply with standard EN 60204, which stipulates in particular that electrical actuators (which include VARMECA 30) cannot be regarded as circuit-breaking devices and certainly not as isolating switches.

Commissioning can take place only if the requirements of the Electromagnetic Compatibility Directive (89/336/EEC, modified by 92/31/EEC) are met.

VARMECA 30 motors meet the requirements of the Low Voltage Directive 73/23/EEC, modified by 93/68/EEC. The harmonised standard of the DIN VDE 0160 series in connection with standard VDE 0660, part 500 and EN 60146/VDE 0558 are also applicable.

The technical characteristics and instructions concerning the connection conditions specified on the nameplate and in the documentation provided must be observed without fail.

3 - Transportation, storage

All instructions concerning transportation, storage and correct handling must be observed.

The climatic conditions specified in the technical manual must be observed.

4 - Installation

The installation and cooling of equipment must comply with the specifications in the manual supplied with the product.

VARMECA 30 motors must be protected against excessive stress. In particular, there must be no damage to parts and/or modification of the clearance between components during transportation and handling. Avoid touching the electronic components and contact parts.

VARMECA 30 motors contain parts which are sensitive to electrostatic stress and may be easily damaged if handled incorrectly. Electrical components must not be exposed to mechanical damage or destruction (risks to health!).

5 - Electrical connection

When work is performed on VARMECA 30 motors which are powered up, national accident prevention specifications must be respected.

The electrical installation must comply with the relevant specifications (for example conductor cross-sections, protection via fused circuit-breaker, connection of protective conductor). More detailed information is given in the manual. Instructions for an installation which meets the requirements for electromagnetic compatibility, such as screening, earthing, presence of filters and correct insertion of cables and conductors, are given in the documentation supplied with the VARMECA 30. These instructions must be followed in all cases, even if the VARMECA 30 carries the CE mark. Adherence to the limits given in the EMC legislation is the responsibility of the manufacturer of the installation or the machine.

6 - Operation

Installations incorporating VARMECA 30 motors must be fitted with additional protection and monitoring devices as laid down in the current relevant safety regulations: law on technical equipment, accident prevention regulations, etc. Modification of VARMECA 30 motors using control software is permitted.

Active parts of the device and live power connections must not be touched immediately after the VARMECA 30 is powered down, as the capacitors may still be charged. In view of this, the warnings fixed to VARMECA 30 motors must be observed.

During operation, all protective covers must remain closed.

7 - Servicing and maintenance

Refer to the manufacturer's documentation.

VARMECA 30

Variable speed motor or geared motor

Notes

VARMECA 30

Variable speed motor or geared motor

CONTENTS

1 - GENERAL INFORMATION	40
1.1 - General operating principle	40
1.2 - Product name.....	40
1.3 - Characteristics	41
1.4 - Environmental characteristics	43
1.5 - Radio-frequency interference.....	43
1.6 - Description of cables and protection devices.....	46
1.7 - UL conformity	47
1.8 - Weights and dimensions	48
2 - INSTALLATION.....	49
2.1 - General	49
3 - CONNECTIONS	49
3.1 - Wiring precautions	49
3.2 - Control terminal blocks	50
3.3 - Power terminal blocks.....	52
3.4 - Terminal blocks for options	52
3.5 - Wiring diagrams	53
3.6 - Power supply and control for FCR brake motors	57
3.7 - Brake rectified voltage depending on the mains supply.....	58
3.8 - Example of supplying 2 motors, with or without brake, in parallel, with a single VARMECA	59
3.9 - Wiring diagrams for SO VMA and VMA ESFR options	60
4 - COMMISSIONING	62
4.1 - Starting with the power supply	62
4.2 - Starting with remote volt-free contact	62
4.3 - Starting with local run/stop control (BMA 31/32, BMA 33/34 or BMAVAR 31/32, BMAVAR 33/34 OPTION)	62
4.4 - Setting the speed	62
5 - FAULTS-DIAGNOSTICS.....	63
6 - MAINTENANCE	63
6.1 - Care	63
6.2 - Measurements	63
7 - OPERATING EXTENSIONS	64
7.1 - Speed control knob option (B 31/32 or B 33/34).....	64
7.2 - Control knob with integrated run-stop control option (BMA31/32 or BMA 33/34)	64
7.3 - Control knob with forward/reverse/stop control option (BMAVAR 31/32 or BMAVAR 33/34).....	64
7.4 - Internal speed control option (CVI VMA 31/32 or CVI VMA 33/34)	64
7.5 - IP 65 braking resistor option (RF100 – RF 200 – RF 600)	65
7.6 - IP 20 external braking resistor option (RF – BRR – 800 – 200).....	65
7.7 - Electromechanical brake power supply and control option (SO VMA 31/32)	65
7.8 - Additional I/O interface and sequential brake control option (ESFR VMA 31/32).....	65
7.9 - Additional I/O interface and sequential brake control option (ESFR VMA 33/34).....	65
7.10 - Fieldbus options.....	65
7.11 - Encoder feedback option (COD VMA 33/34).....	65
7.12 - Parameter-setting console option (PX LCD).....	66
7.13 - Parameter-setting software option (SOFTVMA 30)	66
7.14 - Operator display option (PAD VMA 30)	66
7.15 - XPress Key	66
7.16 - EMC filter (FLT VMA 33/FLT VMA34)	67
7.17 - EMC filter option (FLT VMA 31M).....	67
7.18 - EMC filter option (FLT VMA 31/32).....	67

en

VARMECA 30

Variable speed motor or geared motor

GENERAL INFORMATION

1 - GENERAL INFORMATION



- This manual describes the characteristics and installation of the VARMECA 31ML, 31M, 31TL, 31T, 32M, 32TL, 32T, 33TL, 33T, 34TL, 34T.
- The VARMECA 30 is designed to operate in an industrial environment. When used with an external EMC filter, the VARMECA 30 complies with standards for residential environment.
- If the run command has been enabled, the motor starts as soon as it is switched on.

1.1 - General operating principle

The VARMECA 30 is the physical association of a 3-phase induction motor and an integrated variable speed drive.

The motor allows all kinds of mounting arrangement (foot or flange) and can be combined with standard gearboxes from the LEROY-SOMER range.

In the standard version, the drive with integrated control does not require any connection other than the power supply.

The options may be used to broaden the application range of the VARMECA 30.

Thanks to the advanced technology of the IGBT power module, very high efficiency and reduced noise levels are possible.

1.2 - Product name

Single-phase power supply 115 V \pm 10% - 50/60 Hz		Single-phase power supply 200/240 V \pm 10% - 50/60 Hz		3-phase power supply 200/240 V \pm 10% - 50/60 Hz		3-phase power supply 400/480 V \pm 10% - 50/60 Hz	
Rating	Power (kW)	Rating	Power (kW)	Rating	Power (kW)	Rating	Power (kW)
31 ML 025	0.25	31 M 025	0.25	31 TL 025	0.25	31 T 025	0.25
31 ML 037	0.37	31 M 037	0.37	31 TL 037	0.37	31 T 037	0.37
		31 M 055	0.55	31 TL 055	0.55	31 T 055	0.55
		31 M 075	0.75	31 TL 075	0.75	31 T 075	0.75
		32 M 090	0.90	32 TL 090	0.90	31 T 090	0.90
		32 M 110	1.1	32 TL 110	1.1	31 T 110	1.1
		32 M 150	1.5	32 TL 150	1.5	32 T 150	1.5
				32 TL 180	1.8	32 T 180	1.8
				32 TL 220	2.2	32 T 220	2.2
				33 TL 300	3	32 T 300	3
				33 TL 400	4	32 T 400	4
				34 TL 550	5.5	33 T 550	5.5
				34 TL 750	7.5	33 T 750	7.5
						34 T 900	9
						34 T 111	11

VARMECA 30

Variable speed motor or geared motor

GENERAL INFORMATION

OPERATING EXTENSIONS	
Designation	Description
B 31/32 or B 33/34	Integrated speed control knob
BMA 31/32 or BMA 33/34	Speed control knob and integrated run-stop control knob
BMAVAR 31/32 or BMAVAR 33/34	Speed control knob and integrated stop forward/reverse control knob
CVI VMA 31/32 or CVI VMA 33/34	Integrated speed control
ESFR VMA 31/32 or ESFR VMA 33/34	Brake control
RF100 – RF200 – RF600	Braking resistor Power 100, 200 and 600 W
RF – BRR – 800 – 200	Braking resistor Power 800 W – External mounting
PX LCD	Parameter-setting console
COD VMA 33/34	Encoder feedback
SOFTVMA 30	Parameter-setting software
PAD VMA 31/32 or PAD VMA 33/34	Local display unit
PX KEY	Copy key
SO VMA 31/32	Fixed brake control and power supply (3-phase supply 400-480 V only)
VMA COM PB 31/32 or VMA COM PB 33/34	Fieldbus: PROFIBUS DP
VMA COM IS 31/32 or VMA COM IS 33/34	Fieldbus: INTERBUS S
VMA COM DT 31/32 or VMA COM DT 33/34	Fieldbus: DEVICENET
VMA COM CN 31/32 or VMA COM CN 33/34	Fieldbus: CAN OPEN
FLT VMA 31M	EMC filter for residential environment – Internal mounting (for VMA 31M)
FLT VMA 31/32	EMC filter for residential environment – Internal mounting (for VMA 31TL/T 32/TL/T)
FLT VMA 33	EMC filter for industrial environment – Internal mounting (for VMA 33 TL/T)
FLT VMA 34	EMC filter for industrial environment – Internal mounting (for VMA 34 TL/T)

1.3 - Characteristics

1.3.1 - Electrical data

Power supply	Single-phase supply 110V -10 % to 120V +10 % 50-60Hz ± 2 % 208V -10 % to 240V +10 % 50-60Hz ± 2 %	3-phase supply 208V -10 % to 240V +10 % 50-60Hz ± 2 % 380V -10 % to 480V +10 % 50-60Hz ± 2 %
Phase voltage imbalance	-	3%
Output voltage	From 0 V to input voltage	From 0 V to input voltage
Power range (kW)	0.25 - 0.37* - 0.55 - 0.75 - 0.9 - 1.1 - 1.5	0.25 - 0.37 - 0.55 - 0.75 - 0.9 - 1.1 - 1.5 - 4 - 5.5 - 7.5** - 9 - 11
Maximum number of power-ups per hour	10	100

*0.37 kW max. for 115 V supply (0,75 kW with 310M rating)

**7.5 kW max. for 230 V supply

1.3.2 - Characteristics and functions

Characteristics	VARMECA 30
Motor frequency variation range	- 10 to 80 Hz at constant torque (factory setting can be modified with parameter-setting option) - 10 to 50 Hz for general applications (factory setting can be modified with parameter-setting option) - 0 to Fmax depending on thermal and mechanical limits (Fmax = 400 Hz ; LEROY-SOMER to be consulted anytime the applications requires the drive to run at more than 150 Hz)
Efficiency	97.5% motor efficiency
Overload	150% of In for 60 s 10 times per hour

VARMECA 30

Variable speed motor or geared motor

GENERAL INFORMATION

Pilot control	VARMECA 30
Speed reference	<ul style="list-style-type: none"> - Analogue reference (0 V or 4 mA) = Minimum speed (10 V or 20 mA) = Maximum speed - 0 to 10 V with integrated potentiometer (B31/32 – B33/34 option) - 0 to 10 V with remote potentiometer - 4 to 20 mA with external reference - Reference with internal potentiometer - Digital references - Fieldbus
Speed regulation	<ul style="list-style-type: none"> - Speed regulation with encoder feedback option for VMA 33 or 34 only - Regulation of a reference with integrated PI loop
Run/Stop	<ul style="list-style-type: none"> - With power supply - With remote volt-free contact - With fieldbus - With local run/stop control
Forward/Reverse	<ul style="list-style-type: none"> - With internal connection on the terminal block - With remote volt-free contact - With fieldbus - With local run/stop control
Stop mode	<ul style="list-style-type: none"> - On ramps (using volt-free contact or integrated control) - Freewheel - With electromechanical brake
Ramps	<ul style="list-style-type: none"> - Ramps adjustable from 0 to 600s
Fieldbus	<ul style="list-style-type: none"> - PROFIBUS DP, INTERBUS S, DEVICENET, CAN OPEN, MODBUS RTU, LS NET

Protection	VARMECA 30
Power	<ul style="list-style-type: none"> - Undervoltage (see notice 3847) - Overvoltage (see notice 3847) - Overloads (see notice 3847) <ul style="list-style-type: none"> .thermal, drive and motor .protection against locked rotor - Short-circuit <ul style="list-style-type: none"> .motor windings - Overspeed (see notice 3847)
Control	<ul style="list-style-type: none"> - Short-circuit on 0-10 V/24 V inputs or outputs
Drive reset	<ul style="list-style-type: none"> - By switching off the VARMECA 30 or by opening/closing the connection between the 24V and ENA (VMA 31/32) terminals or SDI 1 and SDI 2 (VMA 33/34) terminals

VARMECA 30

Variable speed motor or geared motor

GENERAL INFORMATION

1.4 - Environmental characteristics

Characteristics	Level
Index of protection	IP 65
Storage temperature	- 40 °C to + 70 °C Conforming to standard IEC 68-2-1.
Transport temperature	- 40 °C to + 70 °C
Operating temperature	- 20 °C to + 50 °C (with power derated by 1% per °C, above 40 °C)
Altitude	< 1000 m without derating. The maximum authorised altitude is 4000 m, but above 1000 m, the continuous output current should be derated by 1% per additional 100 m over 1000 m (eg: for an altitude of 3000 m, derate by 20%).
Ambient humidity	95% non condensing
Humidity during storage	93%, 40 °C, 4 days
Vibration	- Exposed product: 0.01 g ² /Hz 1 hr in accordance with standard IEC 68-2-34. - Sinusoidal vibration: • VMA 31/32 : 2-9 Hz 3,5 ms ⁻² - 9-100 Hz 10 ms ⁻² • VMA 33/34 : 2-6 Hz 3,5 ms ⁻² - 6-100 Hz 5 ms ⁻² in accordance with standard IEC 68-2-6.
Shocks	Packaged product: 15 g, 6 ms, 500 times/direction in all 6 directions in accordance with standard IEC 68-2-29.
Immunity	Conforming to EN61000-6-2
Radiated and conducted emissions	Conforming to EN50081-2 with internal filter
UL standards	Conforming to UL 508 C (E211799)

1.5 - Radio-frequency interference

1.5.1 - General

Variable speed drives use high-speed switches (transistors, semi-conductors) which switch high voltages (around 550VDC for 3-phase drives) at high frequencies (several kHz). This provides better efficiency and a low level of motor noise.

As a result, they generate radio-frequency signals which may disturb operation of other equipment or distort measurements taken by sensors:

- due to high-frequency leakage currents which escape to earth via the stray capacity of the drive/motor cable and that of the motor via the metal structures which support the motor

- by conduction or feedback of R.F. signals on the power supply cable: conducted emissions
- by direct radiation near to the mains supply power cable or the drive/motor cable: radiated emissions
These phenomena are of direct interest to the user.
The frequency range concerned (radio frequency) does not affect the energy distribution company.



Conformity of the drive is only assured when the mechanical and electrical installation instructions described in this manual are adhered to.

VARMECA 30

Variable speed motor or geared motor

GENERAL INFORMATION

1.5.2 - Standards (Emission)

The maximum emission level is set by the generic industrial (EN 50081-2) and residential (EN 50081-1) standards. VARMECA 30 conforms to the following standards:
EN 50081-2, EN 61000-6-4 - EN 61800-3, IEC 61800-3.

Emission				
Standard	Description	Application	Conformity conditions according to the switching frequency	
			With EMC filter	
			Internal	External
EN 61800-3	Variable speed drive standards	Second environment with unrestricted distribution (DENR)	VMA 31/32 \leq 10kHz VMA 33/34 \leq 11kHz	VMA 31/32 \leq 10kHz VMA 33/34 \leq 11kHz
		Second environment with restricted distribution (DER)	VMA 31/32 \leq 10kHz VMA 33/34 \leq 11kHz	VMA 31/32 \leq 10kHz VMA 33/34 \leq 11kHz
		First environment with unrestricted distribution (R)	-	VMA 31/32 \leq 4kHz VMA 33/34 \leq 4,5kHz
		First environment with restricted distribution (I)	VMA 31/32 \leq 4kHz VMA 33/34 \leq 4,5kHz	VMA 31/32 \leq 10kHz VMA 33/34 \leq 11kHz
EN 50081-1 EN61000-6-3	Generic emission standards for residential, commercial and light industrial environments	A.C. supply	-	VMA 31/32 \leq 4kHz VMA 33/34 \leq 11kHz
EN 50081-2 EN 61000-6-4	Generic emission standards for the industrial environment	A.C. supply	VMA 31 \leq 8kHz VMA 32 \leq 4kHz VMA 33/34 \leq 4,5kHz	VMA 31/32 \leq 10kHz VMA 33/34 \leq 11kHz

 **The second environment includes industrial networks supplied with low voltage but which do not serve buildings for domestic use. Operation of a drive without an EMC filter in this type of environment may result in interference on certain electronic appliances located near the drive whose immunity level might not be compatible with industrial conditions. If it proves impossible to filter the disturbed element, add an external EMC filter.**

VARMECA 30

Variable speed motor or geared motor

GENERAL INFORMATION

1.5.3 - Standards (Immunity)

The minimum immunity level is set by the generic industrial (EN 51000-6-2) and residential (EN 51000-6-1) standards. VARMECA 30 conforms to the following standards:

EN 61000-4-2, IEC 61000-4-2 - EN 61000-4-3, IEC 61000-4-3 - EN 61000-4-5, IEC 61000-4-5 - EN 61000-4-6, IEC 61000-4-6 EN 61000-4-11, IEC 61000-4-11 - EN 61000-6-2, IEC 61000-6-2 - EN 61000-3, IEC 61000-3.

Immunity			
Standard	Description	Application	Conformity
IEC 61000-4-3 EN 61000-4-3	Immunity standards for radiated radio-frequency	Product casing	Level 3 (industrial)
IEC 61000-4-6 EN 61000-4-6	Generic immunity standards for conducted radio-frequency	Control and power cables shielded cables outside product	Level 3 (industrial)
EN 50082-1 IEC 61000-6-1 EN 61000-6-1	Generic immunity standards for residential, commercial and light industrial environments	-	Conforms
EN 50082-2 IEC 61000-6-2 EN 61000-6-2	Generic immunity standards for the industrial environment	-	Conforms
EN 61800-3 IEC 61000-6-2 EN 61000-6-2	Variable speed drive standards	Conforms to the first and second environment	
EN 61000-4-4	Bursts of fast transients	Control cable	Level 4 (hardened industrial)
		Power cable	Level 3 (industrial)
EN 61000-4-5	Shock waves	Phase-earth power supply cable	Level 4
		Phase-to-phase power supply cable	Level 3
		Earth signal circuits (refer to section 1.5.5)	Level 2

1.5.4 - Earth leakage current

Earth leakage currents may depend on the type of EMC filter used. The VARMECA 30 can be supplied with its filter integrated and wired-up. The levels of leakage current also depend on the voltage and/or the power supply frequency and the size of the motor.

In all cases, for conformity with immunity standards, a voltage limiting device is connected to earth. The shunt current is negligible in normal circumstances.

1.5.4.1 - use of earth leakage detector (residual current device)

- 1- Type AC: which detects AC faults. Not to be used with variable speed drives.
- 2- Type A: which detects AC faults and pulsed DC faults (provided that the DC is cancelled out at least once per cycle). Only for use with single-phase drives.
- 3 - Type B: which detects AC faults, pulsed DC faults and smoothed DC faults. **Only this type is suitable for use with all variable speed drives.**

Note: If an external EMC filter is being used, a delay of 50 ms should be incorporated to avoid spurious faults being taken into account.

1.5.5 - Control cable immunity

Control cable immunity can be increased outside the VARMECA 30 by one of the following 2 methods:

- Use of shielded twisted pair cable, with shielding connected to earth around its circumference within 100 mm of the VARMECA 30.
- Passing the cable through a ferrite ring at 100 mm maximum distance from the VARMECA 30.

Note: Several control cables can pass through a single ferrite.

1.5.6 - Control circuit immunity when overvoltage occurs

Immunity to overvoltages in control circuits or in long cables connected to the outside of a building.

The various drive input and output circuits conform to standard EN61000-6-2 (1 kV) relating to overvoltages.

There are some exceptions, where the installation may be exposed to overvoltage peaks which exceed the levels determined by the standard. This may be the case in the event of lightning strikes or earth faults associated with long cable lengths (>30 m). To limit the risks of damage to the drive, the following precautions could be taken:

VARMECA 30

Variable speed motor or geared motor

GENERAL INFORMATION

- Galvanic isolation of the I/O.
- Duplication of the cable shielding with an earth wire of 10 mm² minimum. The cable shielding and the earth wire must be linked at both ends and connected to earth with the shortest possible connection. This stratagem enables high currents to pass into the earth wire, rather than into the shielding
- Reinforcement of the logic and analogue I/O protection by adding a zener diode or a peak limiter.

Elimination of uni-directional logic and analogue I/O overvoltages

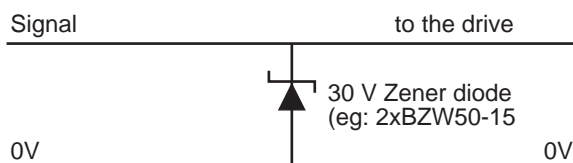

These circuits are available in modules (DIN rail mounting). These circuits are not suitable for encoder signals or for high-speed logic data networks, because the diodes may affect the signal. The majority of encoders have galvanic isolation between the motor casing and the encoder circuit, and in this case, no precautions are necessary. For data networks, follow the specific network recommendations.

If a logic output is subjected to significant overvoltages, the drive trips on an "Old1" fault.

1.6 - Description of cables and protection devices

! It is the responsibility of the user to connect and provide protection for the VARMECA 30 in accordance with the legislation and regulations in force in the country of use. This is particularly important as regards the size of cables, the type and rating of fuses, the earth or ground connection, powering down, acknowledging faults, insulation and protection against overcurrents.

- These tables are given for information only, and must under no circumstances be used in place of the current standards.
- When using a circuit-breaker, it must be a motor circuit-breaker (D curve).
- The residual current device must be type B. Too many devices connected to a single residual current device can cause it to trip. Check that the circuit-breaker is only protecting the VARMECA.
- Comply with the size of protection fuses.

P (kW)	Single-phase power supply 110V - 10 % to 120V + 10 %					Single-phase power supply 208V - 10 % to 240V + 10 %				
	VMA rating	Fuses (gG)	I (A)	Cables (mm ²)	PE	VMA rating	Fuses (gG)	I (A)	Cables (mm ²)	PE
0.25	31 ML 025	8	6.8	1.5	M16 + M20	31 M 025	8	3.5	1.5	M16 + M20
0.37	31 ML 037	10	8.5	1.5	M16 + M20	31 M 037	10	4	1.5	M16 + M20
0.55						31 M 055	10	4.5	1.5	M16 + M20
0.75						31 M 075	16	7	2.5	M16 + M20
0.9						32 M 090	16	9	2.5	M16 + M20
1.1						32 M 110	20	11	2.5	M16 + M20
1.5						32 M 150	25	14	2.5	M16 + M20

VARMECA 30

Variable speed motor or geared motor

GENERAL INFORMATION

P (kW)	Three-phase power supply 208V - 10 % to 240V + 10 %					Three-phase power supply 380V - 10 % to 480V + 10 %				
	VMA rating	Fuses (gG)	I (A)	Cables (mm ²)	PE	VMA rating	Fuses (gG)	I (A)	Cables (mm ²)	PE
0.25	31 TL 025	4	2	1.5	M16 + M20	31 T 025	4	1	1.5	M16 + M20
0.37	31 TL 037	6	3	1.5	M16 + M20	31 T 037	4	1.5	1.5	M16 + M20
0.55	31 TL 055	6	4	1.5	M16 + M20	31 T 055	6	2	1.5	M16 + M20
0.75	31 TL 075	8	5	1.5	M16 + M20	31 T 075	6	3	1.5	M16 + M20
0.9	32 TL 090	10	5.5	1.5	M16 + M20	31 T 090	8	3.5	1.5	M16 + M20
1.1	32 TL 110	10	6	2.5	M16 + M20	31 T 110	10	4	1.5	M16 + M20
1.5	32 TL 150	16	7	2.5	M16 + M20	32 T 150	10	5	1.5	M16 + M20
1.8	32 TL 180	16	7.5	2.5	M16 + M20	32 T 180	10	5.5	2.5	M16 + M20
2.2	32 TL 220	16	8	2.5	M16 + M20	32 T 220	10	6	2.5	M16 + M20
3	33 TL 300	16	12	2.5	M20 + M25	32 T 300	16	7	2.5	M16 + M20
4	33 TL 400	20	15	4	M20 + M25	32 T 400	16	8	2.5	M16 + M20
5.5	34 TL 550	25	20	4	M20 + M25	33 T 550	16	12	2.5	M20 + M25
7.5	34 TL 750	32	24	4	M20 + M25	33 T 750	20	16	4	M20 + M25
9						34 T 900	25	19	4	M20 + M25
11						34 T 111	32	22	4	M20 + M25

Note:

- The mains current value is a typical value which depends on the source impedance. The higher the impedance, the lower the current.
- The fuses (UL approved) are intended for installations capable of delivering 5000 A maximum at 480 V.

1.7 - UL conformity

1.7.1 - Specified mains supply

The drive can be incorporated in an installation which can deliver 5000 A rms maximum at a voltage of 264 VAC rms maximum for 230 V (TL) drives or 528 VAC rms maximum for 400 V (T) drives.

1.7.2 - Cables

Only class 1 copper cables 60/75 °C (140/167 °F) should be used.

1.7.3 - Fuses

UL conformity is adhered to if the fuses used are UL-listed, fast-blow fuses (class CC up to 30 A) with a rating as indicated in the above table, and if the short-circuit symmetrical current does not exceed 5 kA.

VARMECA 30

Variable speed motor or geared motor

GENERAL INFORMATION

1.8 - Weights and dimensions

Type	VMA rating	Dimensions (mm)							Weight (kg)
		HJ	LJ			J	I	II*	
			B3	B5	B14				
LS 71	31ML-31M - 31TL - 31T	176	8	8	8	217	75	94	4.2
LS 80 L	31ML-31M - 31TL - 31T	190	12	12	12	217	75	94	4.2
	32M - 32TL	190	12	12	12	232	75	94	4.2
LS 90 S/L	31T	199	12	32	13	217	75	94	4.2
	32M - 32 TL	199	12	32	13	232	75	94	4.2
LS 100 L	32TL - 32T	205	12	12	12	232	75	94	4.2
	33TL	270	4	4	4	336	115	141	8.1
LS 112 M	32T	204	12	12	12	232	75	94	4.2
	33TL	270	4	4	4	336	115	141	8.1
LS 112 MG	32T	213	21	21	21	232	75	94	4.2
	33TL	280	13	13	13	336	115	141	8.1
LS 132 S	32T	213	39	39	39	232	75	94	4.2
	33TL - 33T	280	30	30	30	336	115	141	8.1
LS 132 M	33T - 34TL - 34T	300	8	8	8	336	115	141	8.1
LS 160 M/MR	34T	309	38	38	38	336	115	141	8.1

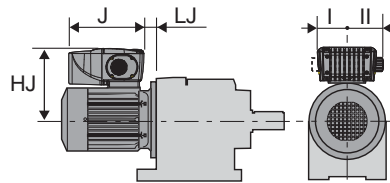

VARMECA 30

Variable speed motor or geared motor

INSTALLATION

2 - INSTALLATION

- It is the responsibility of the owner or user to ensure that the installation, operation and maintenance of the drive and its options comply with legislation relating to the safety of people and equipment and with the regulations in force in the country of use.
- Before carrying out any work, disconnect and lock the drive power supply. For the single-phase range, wait 2 minutes to make sure that the capacitors have discharged.
- After connection, ensure that the seals are firmly in place, and that the screws and cable glands are watertight to ensure IP 65 protection.
- Holes are provided at the lowest points of the enclosure, depending on the operating position, to drain off any moisture that may have accumulated inside during cooling of the machine. In conditions which encourage the formation of condensation, it is advisable to leave the drain holes permanently open.

- When the cover is open, the VARMECA 30 degree of protection is IP10. Any work should only be carried out by experienced, qualified personnel.

2.1 - General

The VARMECA 30 motor is fitted to the machine like a standard motor, with flange or foot mounting. The motor ventilation cools the whole assembly. Make sure that the ventilation air inlet is free of obstruction. The positions of the potentiometer/cable gland supports are specified at the time of ordering. However they may be reversed if necessary.

3 - CONNECTIONS

- All connection work must be performed in accordance with the laws in force in the country where the drive is installed. This includes earthing to ensure that no directly accessible part of the drive can be at the mains voltage or any other voltage which may be dangerous.
- The voltages on the cables or connections of the mains supply, the motor, the braking resistor or the filter may cause fatal electric shocks. Contact must be avoided in all circumstances.
- The drive must be supplied via a circuit-breaking device so that it can be powered down safely.
- The drive contains capacitors which remain charged at a fatal voltage even after the power supply has been cut off.
- Wait 2 minutes after powering down the drive before removing the protection devices.
- The drive power supply must be protected against overloads and short-circuits.
- It is vital to respect the rating of protection devices.
- Connection with copper conductor only.
- Check that the voltage and current of the drive, the motor and the mains supply are compatible.
- After the drive has been operating, the heatsink or the braking resistors may be very hot (avoid touching them).

- Check that the different earth points are actually at the same voltage.
- Incorporate a bend where the cables enter the cable glands so that water cannot penetrate the terminal box.
- Tighten the cable gland firmly.

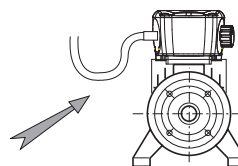

- The VARMECA 30 has a positive logic configuration. Using a drive with a control system which has a different control logic may cause unwanted starting of the motor.
- The control circuits in the drive are isolated from the power circuits by single insulation (IEC 664-1). The installer must ensure that the external control circuits are isolated against any human contact.
- If the control circuits need to be connected to circuits conforming to SELV safety requirements, additional insulation must be inserted to maintain the SELV classification.

3.1 - Wiring precautions

- When the VARMECA 30 is controlled remotely, avoid parallel routing of power cables and control cables.
- All remote control cables must be shielded and have a cross-section between 0.22 mm² and 1 mm². The shielding should be connected to earth at both ends.

VARMECA 30

Variable speed motor or geared motor

CONNECTIONS

3.2 - Control terminal blocks

 • Check that the terminal block has been removed from its fixed holder (unplugged) before making any connections, so as to avoid putting pressure on the card.

- The VARMECA has a positive logic configuration. Using a drive with a control system which has a different control logic may cause unwanted starting of the motor.
- The control circuits in the drive are isolated from the power circuits by single insulation (IEC 664-1).

The installer must ensure that the external control circuits are isolated against any human contact.

- If the control circuits need to be connected to circuits conforming to SELV safety requirements, additional insulation must be inserted to maintain the SELV classification.

Removable screw terminal block:

- Tightening torque = 0.3 N.m
- Max. cross-section = 1.5 mm²

VMA terminal 33/34	VMA terminal 31/32	Designation	Function	Characteristics	
1	1	10V	+10V analogue internal source	Accuracy	± 2%
				Maximum output current	30 mA
2	2	AD11	Analogue or logic input 1 Assignment in standard configuration: 0-10V speed reference	Voltage input	
				Full scale voltage	10 V ± 2%
				Input impedance	95 kΩ
				Current input	
				Current range	0 to 20 mA ± 5%
				Input impedance	500 Ω
				Resolution	10 bits
				Sampling	6 ms
				Logic input (if connected to the +24V)	
				Thresholds	"0": < 5 V – "1": > 10 V
				Voltage range	0 to +24 V
				Load	95 kΩ
Input threshold	7.5 V				
3	3	0V	Logic circuit common 0V		
4	4	AD12	Analogue or logic input 2 Assignment in standard configuration: Motor PTC input	Voltage input	
				Full scale voltage	10 V ± 2%
				Input impedance	95 kΩ
				Current input	
				Current range	0 to 20 mA ± 5%
				Input impedance	500 Ω
				Resolution	10 bits
				Sampling	6 ms
				Logic input (if connected to the +24V)	
				Thresholds	"0": < 5 V – "1": > 10 V
				Voltage range	0 to +24 V
				Load	95 kΩ
				Input threshold	7.5 V
				Input (PTC)	
				Trip	≥ 3300 Ω
Cleared fault threshold	< 1800 Ω				
5	NA	0V	Logic circuit common 0V		

VARMECA 30

Variable speed motor or geared motor

CONNECTIONS

VMA terminal 33/34	VMA terminal 31/32	Designation	Function	Characteristics	
6	6	ADIO3	Analogue or logic input or analogue output 3 Assignment in standard configuration: Analogue output (LED control option for VMA 31 up to 34)	Characteristics	Analogue voltage (common mode) or uni-directional
				Voltage input	
				Full scale voltage	10 V ± 2%
				Input impedance	95 kΩ
				Current input	
				Current range	0 to 20 mA ± 5%
				Input impedance	500 Ω
				Resolution	10 bits
				Sampling	6 ms
				Logic input (if connected to the +24V)	
				Thresholds	"0": < 5 V – "1": > 10 V
				Voltage range	0 to +24 V
				Load	95 kΩ
				Input threshold	7.5 V
				Voltage output	
				Voltage range	0 to 10 V
				Load resistor	2 kΩ
				Protection	Short-circuit (40 mA max)
				Current output (VMA 33/34 only)	
				Current range	0 to 20 mA
Maximum voltage	10 V				
Load resistor	500 Ω				
7	7	DIO1	Digital input or output 1 Assignment in standard configuration: External fault management	Characteristics	Digital input or output 1
				Thresholds	"0": < 5 V – "1": > 10 V
				Voltage range	0 to +24 V
				Sampling/refreshment	2 ms
				Digital input	
				Absolute maximum voltage	0 to +35 V
				Load	15 kΩ
				Input threshold	7.5 V
				Logic output	
				Maximum output current	50 mA
Overload current	50 mA				
8	5	24V	+24V internal source	Output current	10 mA in total
				Overload current	VMA 33/34: 150 mA - VMA 31/32: 50 mA
11	11			Accuracy	± 5%
				Protection	Current limiting and setting to fault mode
9	8	DI2	Logic input 2 Assignment in standard configuration: Run forward	Characteristics	Logic input (positive logic)
				Thresholds	"0": < 5 V – "1": > 10 V
				Voltage range	0 to +24 V
10	9	DI3	Logic input 3 Assignment in standard configuration: Run reverse	Sampling/refreshment	2 ms
				Absolute maximum voltage range	0 to +35 V
12	10	DI4	Logic input 4 Assignment in standard configuration: Selection of ADI1	Load	15 kΩ
				Input threshold	7.5 V
13	NA	SDI1	+24V dedicated to the safety input	Characteristics	Logic input (positive logic)
				Thresholds	"0": < 5 V – "1": > 18 V
14	12	SDI2/ENA	Safety/unlocking input	Voltage range	9 to +33 V
				Impedance	820 Ω
15	13	COM/RL1	Fault relay output	Characteristics	VMA 33/34: NO_NC single-pole changeover contact VMA 31/32: NO single-pole contact
16	NA	RL1C		250 VAC maximum contact current	- 4 A, resistive load
17	14	RL10/RL2			- 2 A, inductive load
18	NA	SDO1	Safety contact	Characteristics	NO single-pole changeover contact
19	NA	SDO2		250 VAC maximum contact current	- 4 A, resistive load - 2 A, inductive load

VARMECA 30

Variable speed motor or geared motor

CONNECTIONS

3.3 - Power terminal blocks

3.3.1 - Terminal block for power supply PB1 (marked L1, L2 and L3)

This terminal block is used to connect the 3-phase power supply when the EMC filter is not supplied with the VARMECA 30. Otherwise, the EMC filter output is screwed onto this connector and the power supply should be attached to the terminals located on top of the filter.

Screw terminal block:	VMA 33/34	VMA 31/32
Tightening torque	1.8 N.m	0.8 Nm
Max. cross-section	4 mm ² (AWG8)	2.5 mm ²

3.3.2 - Terminal block for braking resistor PB2 (marked R+ and R-)

This terminal block is used to connect a braking resistor when this option is required. The resistor is mounted on the outside and/or the rear of the VARMECA 30 casing.

Screw terminal block:	VMA 33/34	VMA 31/32
Tightening torque	1.8 N.m	0.8 Nm
Max. cross-section	4 mm ² (AWG8)	2.5 mm ²

⚠ Note: For the VMA 31/32, PB1 and PB2 are both located on the same terminal block.

The terminal block on the VARMECA 31/32 has a terminal marked FI connected to the R- terminal which enables use of the internal braking resistor. The jumper must be removed when an external braking resistor is connected or if the inertia is incompatible with the rated deceleration ramp.

VMA 31/32

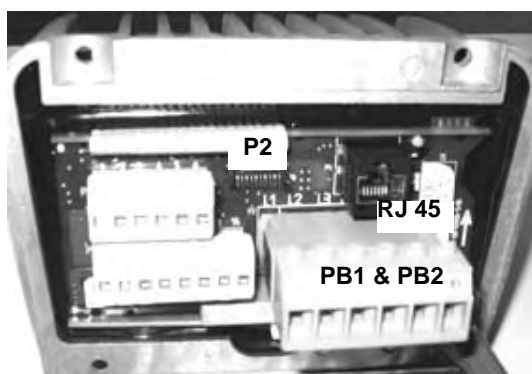

3.4 - Terminal blocks for options

3.4.1 - RS485 type serial link connector

This is an RJ 45 connector and is used to connect the PX LCD console or a PC in order to use the PEGASE VMA 30 programming software.

For the VMA 31/32 it is also used to connect the fieldbus or the PADVMA 31/32 option.

3.4.2 - Description of Slot 1 (VMA 33/34 only)

This slot is used to connect the encoder feedback module (option: COD VMA 30) when "closed loop" mode is selected.

3.4.3 - Description of Slot 2 (VMA 33/34 only)

This slot is used to connect one of the fieldbus modules (protocols supported: PROFIBUS DP, INTERBUS S, DEVICE NET and CAN OPEN).

3.4.4 - P2 connector (VMA 31/32 only)

This is used to connect the following options: Local potentiometer (B 31/32), local potentiometer with integrated Run/Stop (BMA 31/32), local potentiometer with integrated Forward/Reverse/Stop (BMAVAR), Brake control (ESFRVMA 30), etc.

VMA 33/34

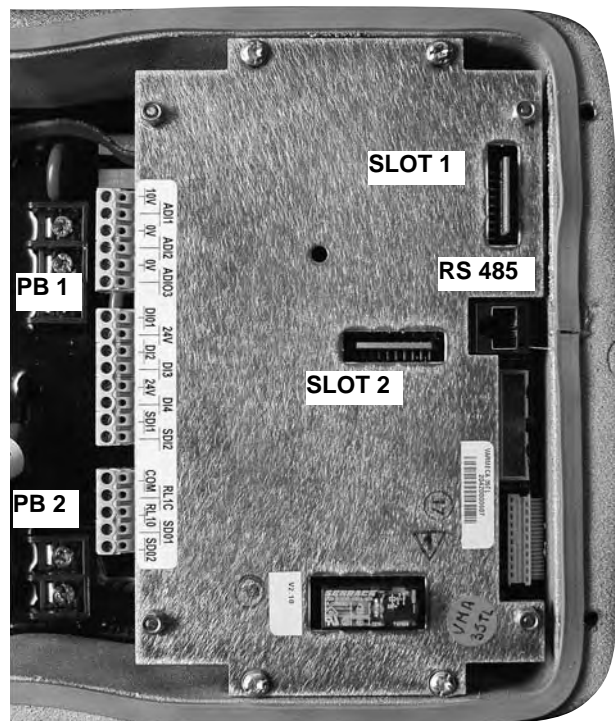

VARMECA 30

Variable speed motor or geared motor

CONNECTIONS

3.5 - Wiring diagrams

3.5.1 - Standard configuration connection diagram

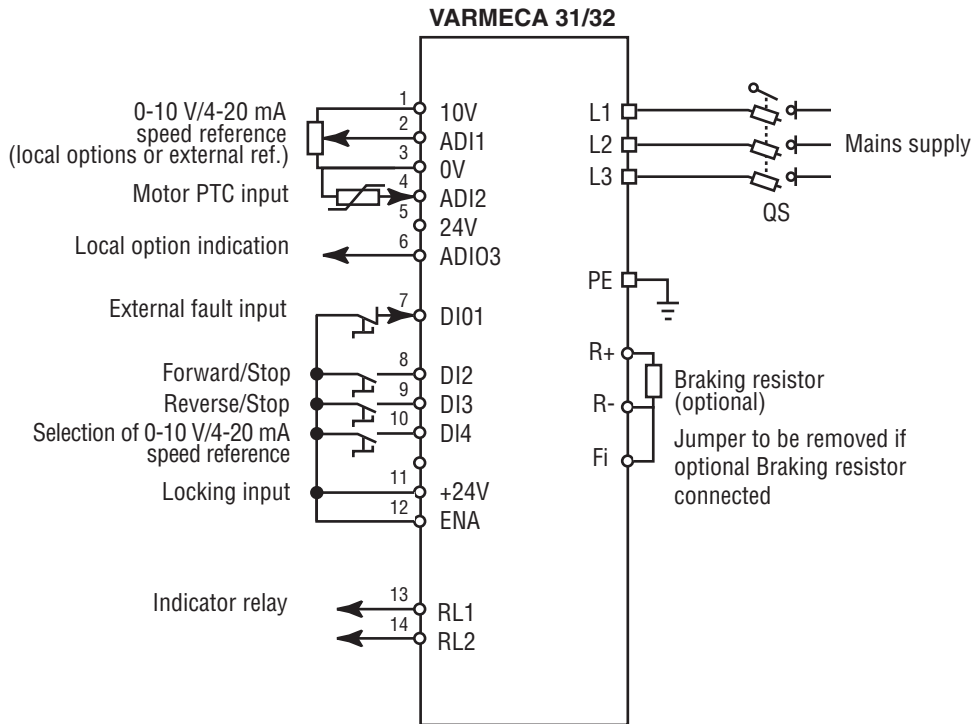

Note:

For single-phase versions, the power supply is connected to terminals L and N.

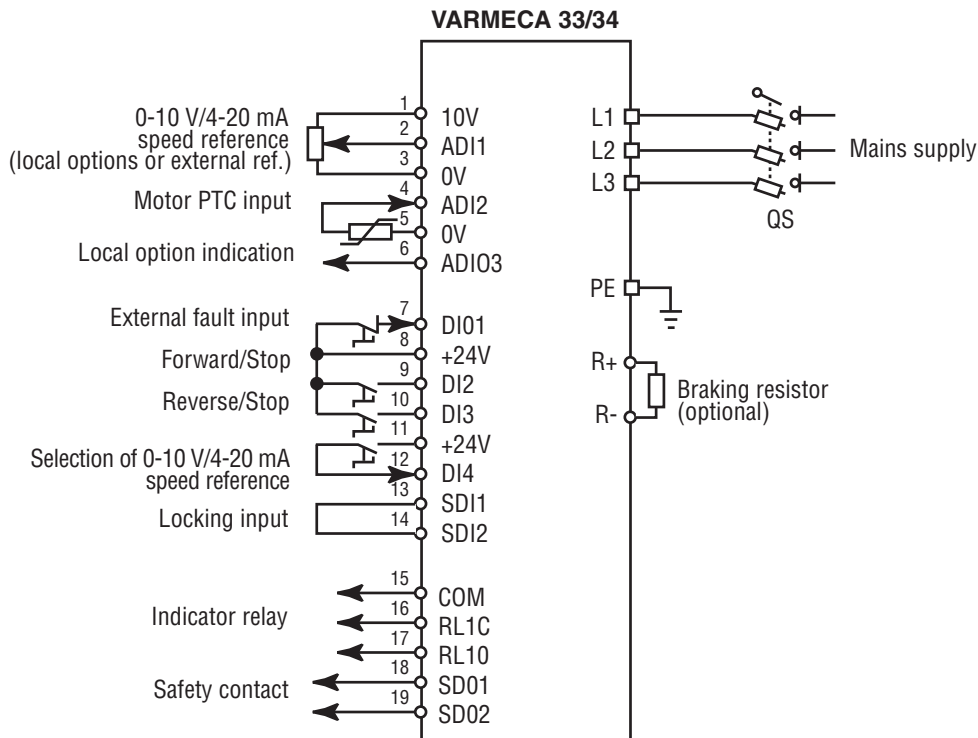

VARMECA 30

Variable speed motor or geared motor

CONNECTIONS

3.5.2 - Connection diagram with safety input

3.5.2.1 - Safety input

This input, when opened, causes the drive to lock. Independent of the microprocessor, it acts on several levels of control from the power bridge. It is designed in such a way that even if one or more circuit components were to fail, the absence of torque on the motor shaft is guaranteed with a very high level of integrity.

This input is used to create a safety function using the principles of category 1 or 3 of standard EN954-1, depending on the application diagram.

The design of the "freewheel stop" function using input SDI2 has been evaluated by CETIM.

The results of this examination are recorded in report no. 732773/47A.

This built-in functionality enables the drive to act as substitute for a contactor in order to stop the motor in freewheel mode.

By using this safety input redundantly with another drive logic input, a diagram can be used which is capable of resisting a single fault. The drive will stop the motor in freewheel mode using two different control channels.

For correct use, the power connection diagrams described in the following paragraphs must be adhered to.

To unlock the drive and provide the safety function, safety input ENA (VMA 31/32) or SDI2 (VMA 33/34) must be connected to the +24V source (SDI1 for VMA 33/34).

This +24V source should be reserved exclusively for the safety input function (VMA33/34).



• The safety input is a safety component which must be incorporated into the complete system dedicated to machine safety. As for any installation, the complete machine must be the subject of a risk analysis by the integrator which will determine the safety category with which the installation must comply.

• The safety input, when open, locks the drive, meaning the dynamic braking function is no longer available. If a braking function is required before the drive safety lock is applied, a time-delayed safety relay should be installed to activate locking automatically after the end of braking. If braking needs to be a machine safety function, it should be provided by an electromechanical solution since the dynamic braking by the drive function is not considered to be a safety function.

• The safety input does not provide the electrical isolation function. Before any work is carried out, the power supply must be cut by an approved isolating device (isolator, switch, etc).

• The safety function is not enabled when the drive is controlled via the keypad or via a fieldbus.

VARMECA 30

Variable speed motor or geared motor

CONNECTIONS

3.5.2.2 - 3-phase AC power supply in accordance with safety standard EN954-1 - category 1 with use of safety input

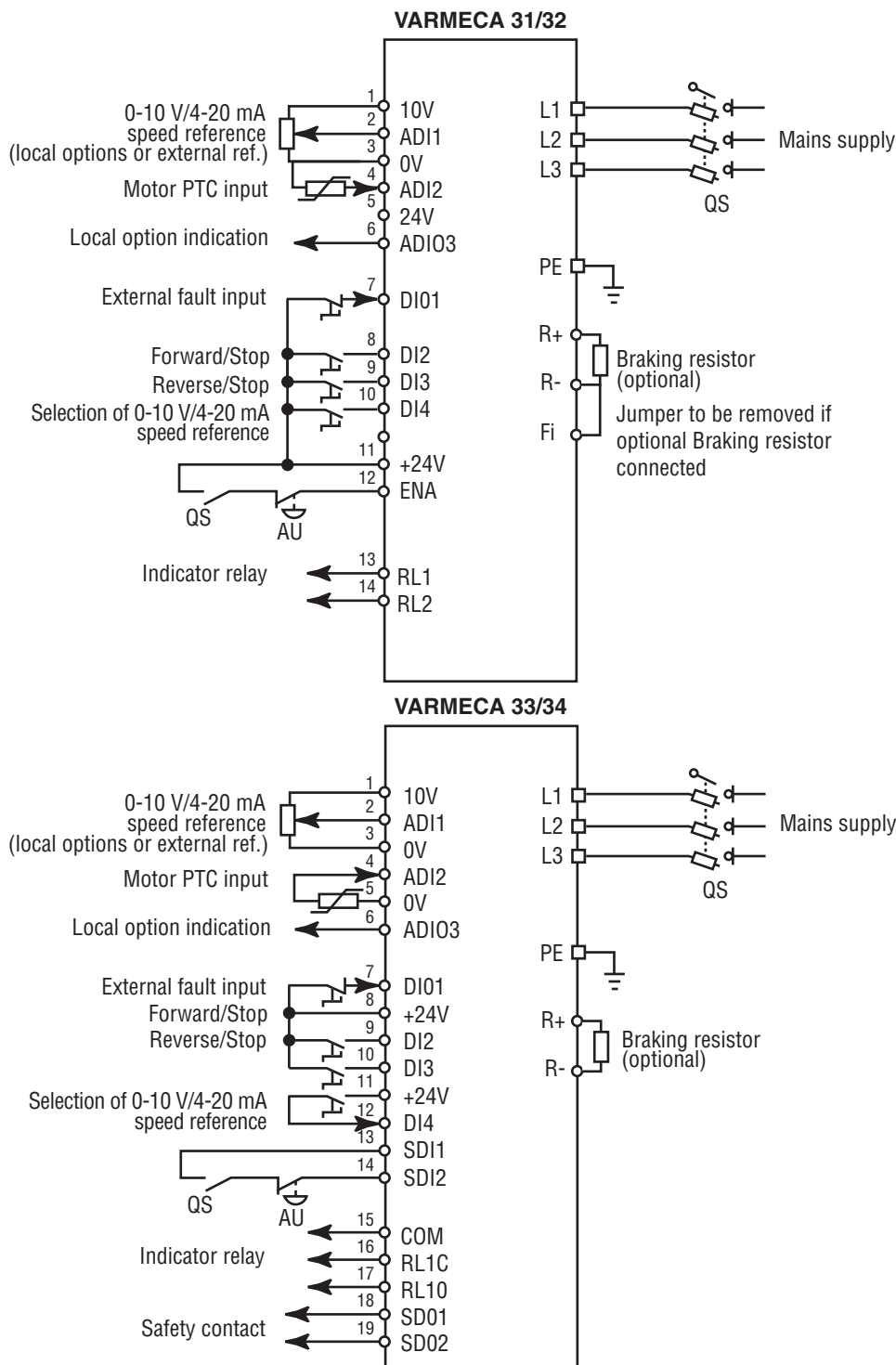

Note:

For single-phase standards, the power supply is connected to terminals L and N.

QS: Fused isolator: QS must be opened before any intervention on the electrical parts of the drive or motor.

AU: Emergency stop button.

Optional braking resistor. Dissipates the active power returned by the motor onto the drive DC bus in the event of a driving machine.

Using the safety input means the motor can be stopped in freewheel mode without using a line contactor. The drive's internal principles are sufficiently safe to perform a stop using the safety input directly (category 1 of EN954-1).

VARMECA 30

Variable speed motor or geared motor

CONNECTIONS

3.5.2.3 - 3-phase AC power supply in accordance with safety standard EN954-1 - category 2 or 3 with use of safety input SDI2 redundantly with logic input DI2

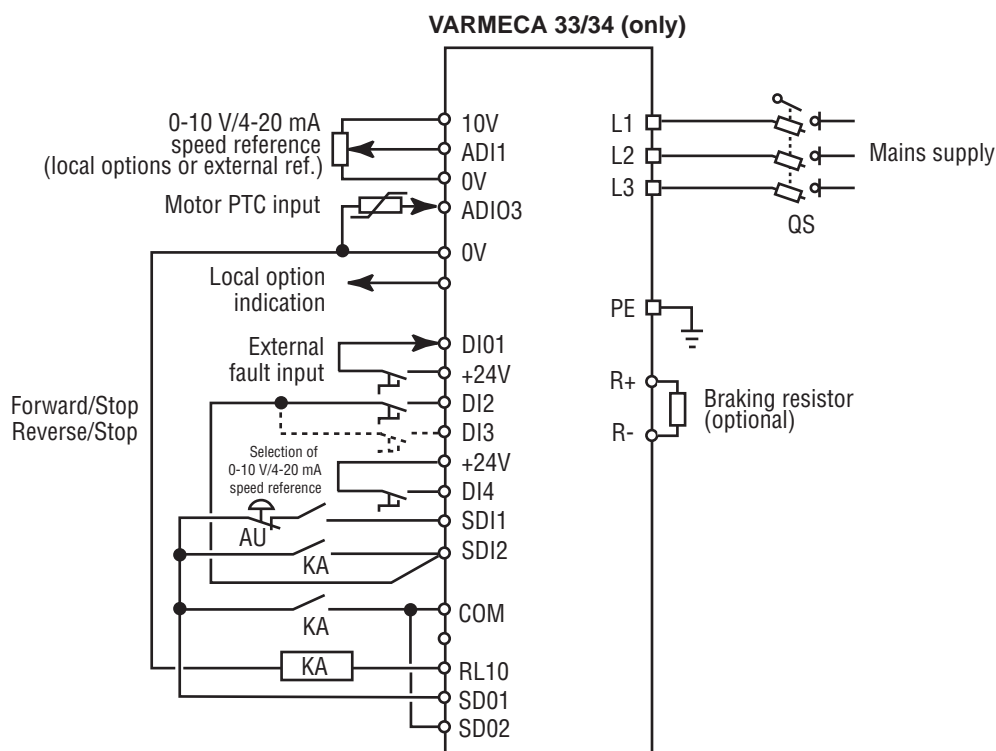

QS: Fused isolator: QS must be opened before any intervention on the electrical parts of the drive or motor.

AU: Emergency stop button.

KA: Relays

Optional braking resistor. Dissipates the active power returned by the motor onto the drive DC bus in the event of a driving machine.

Using the safety input means the motor can be stopped in freewheel mode without using a line contactor. The drive's internal principles are sufficiently safe to perform a stop using the safety input directly (category 1 of EN954-1).

Duplication of the stop command on a logic input enables use of the internal drive redundancy to perform a freewheel stop (application of category 3 principles in accordance with EN954 for the part relating to the drive).

VARMECA 30

Variable speed motor or geared motor

CONNECTIONS

3.6 - Power supply and control for FCR brake motors

3.6.1 - Power supply for the built-in fixed control brake (SO VMA option) VMA 31/32 only

- The brake is supplied via the rectifier fixed on the SO VMA connection card. This connection is made at the factory.
- The rectifier is supplied by a mains phase and the motor star point.
- No parameters need to be set on the VARMECA.
- The brake is released as soon as the VARMECA run command is enabled. The brake is released after a stop command, at the end of the deceleration ramp or on disconnection of the power supply.

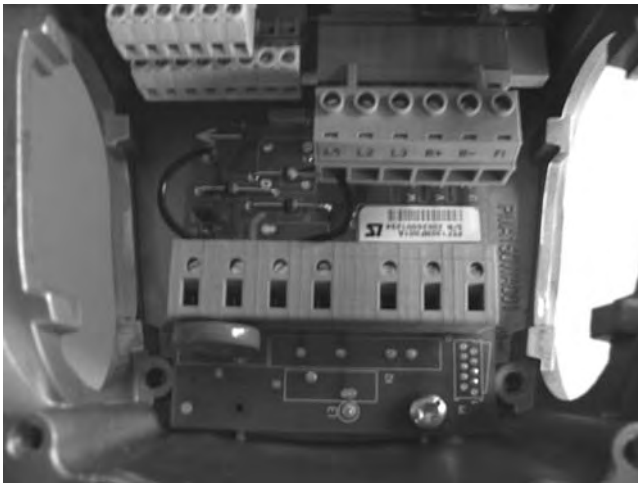

3.6.2 - Power supply for the built-in sequential control brake (VMA ESFR option)

- The brake is supplied via the rectifier and a solid state relay fixed on the VMA ESFR connection card. This connection is made at the factory.
- The rectifier is supplied by two mains phases.
- The brake is controlled according to a sequence which can be adjusted using the VARMECA parameters.

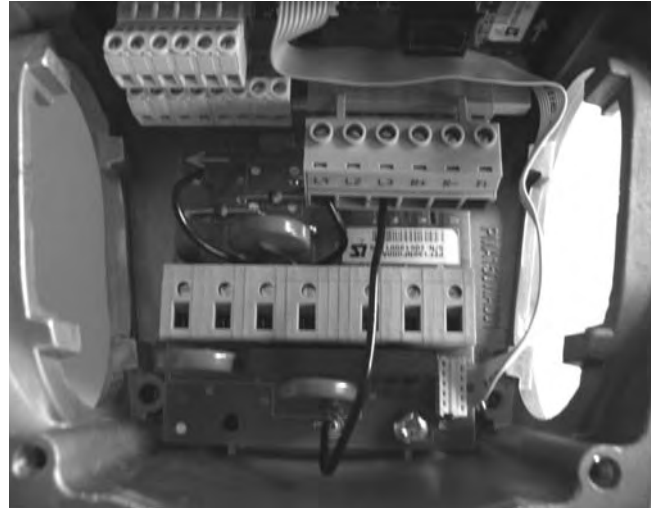

3.6.3 - Separate power supply

The brake is supplied and controlled by an external source.

VARMECA 30

Variable speed motor or geared motor

CONNECTIONS

3.7 - Rectified brake voltage according to the mains supply

Mains	VMA rating	Power (kW)	FCR brake voltage	
			SO VMA option	VMA ESFR option
Single-phase power supply 208V -10% to 240V +10%	31M-025	0.25	NA	180 VDC
	31M-037	0.37		
	31M-055	0.55		
	31M-075	0.75		
	32M-090	0.9		
	32M-110	1.1		
3-phase power supply 208V -10% to 240V +10%	31TL-025	0.25	NA	180 VDC
	31TL-037	0.37		
	31TL-055	0.55		
	31TL-075	0.75		
	32TL-090	0.9		
	32TL-110	1.1		
	32TL-150	1.5		
	32TL-180	1.8		
3-phase power supply 380V -10% to 480V +10%	31T-025	0.25	120 VDC	180 VDC
	31T-037	0.37		
	31T-055	0.55		
	31T-075	0.75		
	31T-090	0.9		
	31T-110	1.1		
	32T-150	1.5		
	32T-180	1.8		
	32T-220	2.2		
	32T-300	3	100 VDC	
3-phase power supply 208V -10% to 240V +10%	33TL-300	3	NA	100 VDC
	33TL-400	4		
	34TL-550	5.5		
	34TL-750	7.5		
3-phase power supply 380V -10% to 480V +10%	33T-550	5.5	NA	180 VDC
	33T-750	7.5		
	34T-900	9		
	34T-111	11		

NA: Not available, provide a separate power supply.

VARMECA 30

Variable speed motor or geared motor

CONNECTIONS

3.8 - Example of supplying 2 motors with or without brake in parallel with a single VARMECA

3.8.1 - The VARMECA must be sized to take account of the total motor power rating

- The flange with 4 cable glands option must be used to make it easier to wire up the 2nd motor.

3.8.2 - The 2nd motor is designed to connect to the terminals marked U, V, W and PE on the SO VMA and VMA ESFR options for VMA 31/32 or on the 2nd motor option for VMA 33/34

3.8.3 - Connecting the brake on the 2nd motor

- With the SO VMA option, the rectifier is supplied between the motor star point and a mains phase from the F1 terminal of the SO VMA 31/32 option.

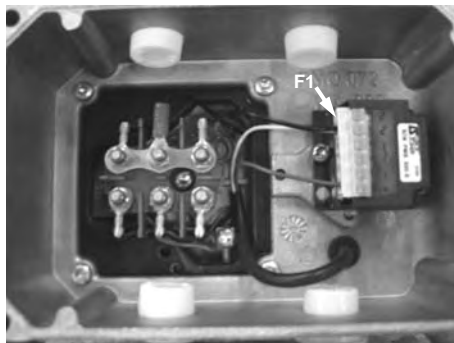

F1 terminal of the SO VMA 31/32 option

- With the VMA ESFR option, the rectifier is supplied between 2 mains phases and the solid state relay; connect it from the F1 and F2 terminals of the VMA ESFR 31/32 to the VMA ESFR 33/34.

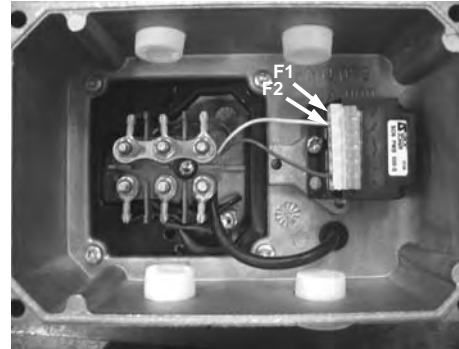

F1 and F2 terminals of the VMA ESFR 31/32 option

VARMECA 30

Variable speed motor or geared motor

CONNECTIONS

3.9 - Wiring diagrams for the SO VMA and VMA ESFR options

3.9.1 - Connection of the SO VMA 31/32 option

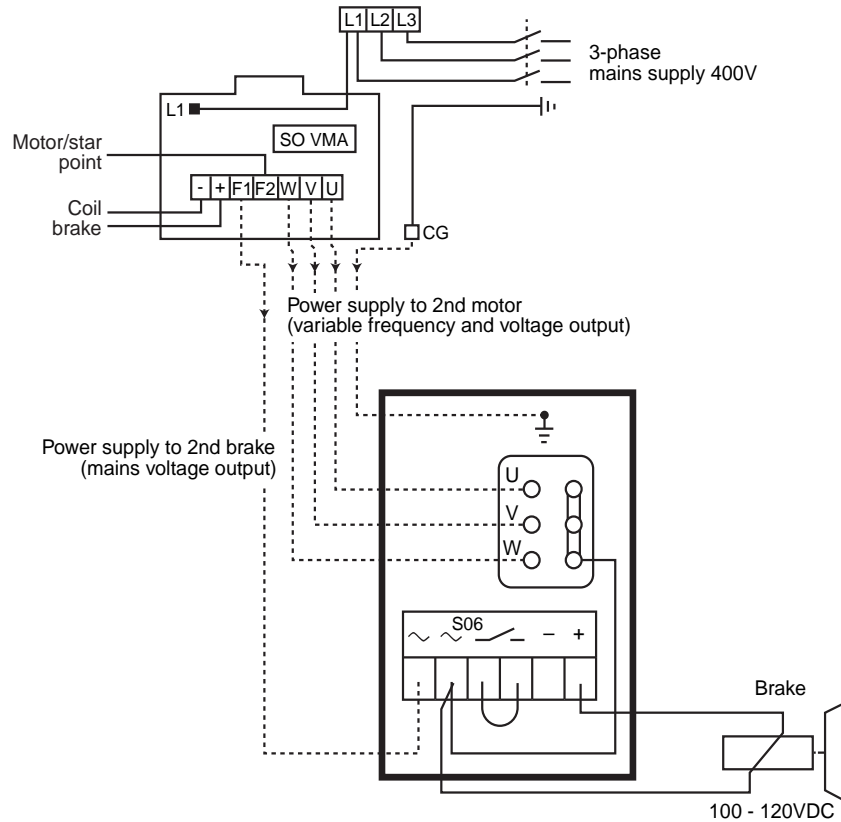

3.9.2 - Connection of the VMA ESFR 31/32 option

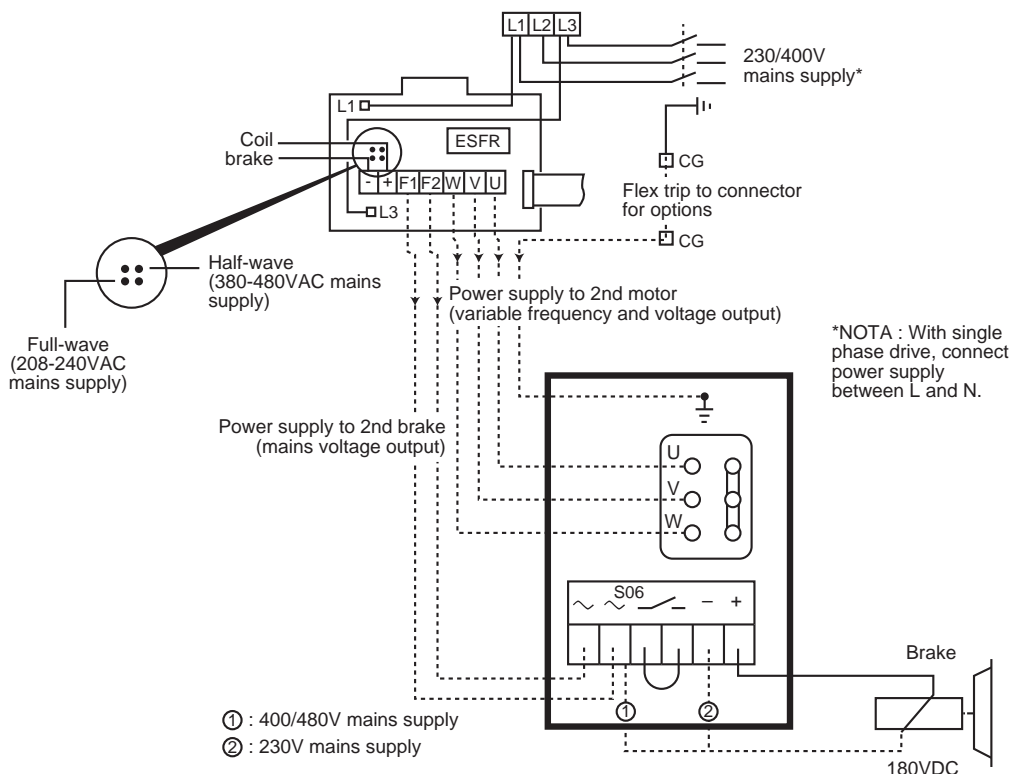

VARMECA 30

Variable speed motor or geared motor

CONNECTIONS

3.9.3 - Connection of the VMA ESFR 33/34 option

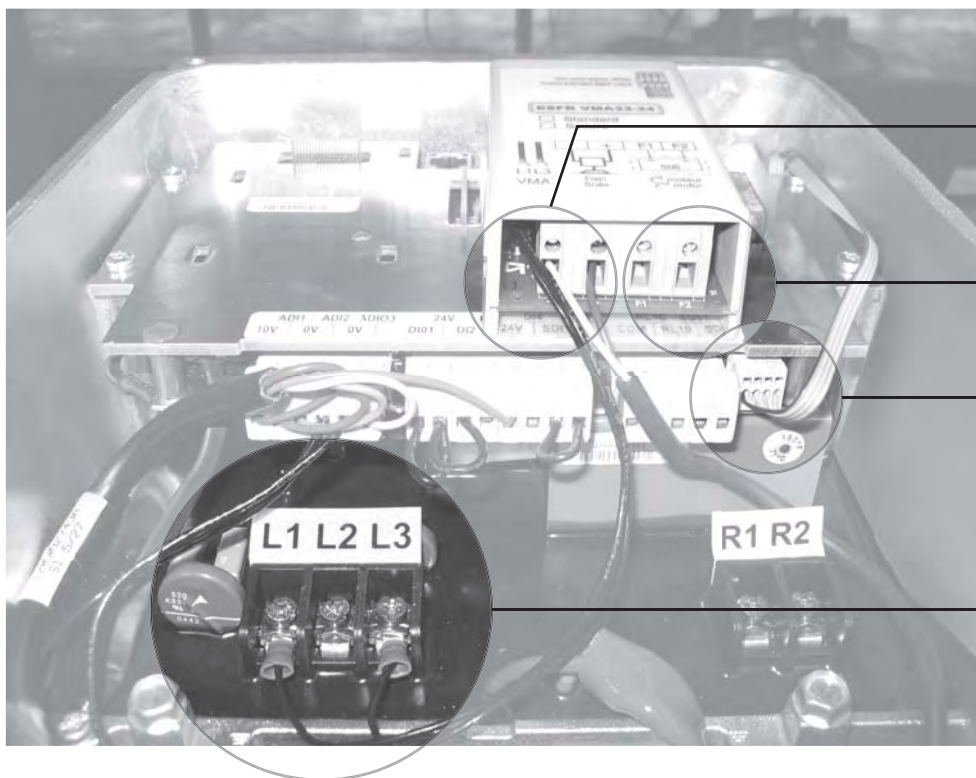
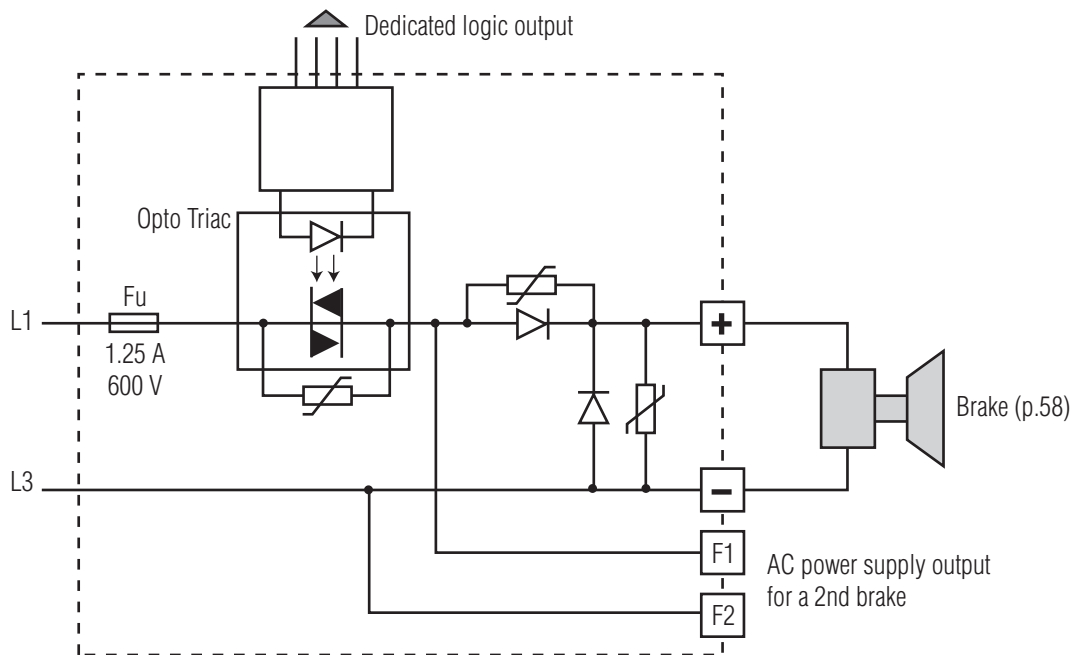

en

VARMECA 30

Variable speed motor or geared motor

COMMISSIONING

4 - COMMISSIONING



- Before switching on the VARMECA 30, check that the electrical connections are correct, and that any moving parts are mechanically protected.
- For the safety of personnel, the VARMECA 30 must not be switched on with the protective cover removed.

4.1 - Starting with the power supply

Since the run command has been factory-enabled via a jumper, the motor starts as soon as it is switched on.

The speed is adjusted with the local control knob (B 31/32 or B 33/34 option) or a remote reference (0-10 V or 4-20 mA).

Power-up: the green indicator lamp is lit continuously.

The control terminals SDI1 and SDI2 (VMA 33/34) or 11 and 12 (VMA 31/32) are linked (unlocking).

4.1.1 - Automatic starting

By leaving the wire between control terminals 8 and 11 (VMA 31/32) or DI2 and +24V (VMA 33/34), the motor starts running forward.

4.2 - Starting with remote volt-free contact

Once it has been switched on, the motor starts in accordance with the run command given by the closing of the volt-free contact corresponding to the desired direction of rotation.

The speed is adjusted with the local control knob (B 31/32 or B 33/34 option) or a remote reference (0-10 V or 4-20 mA).

4.3 - Starting with local run/stop control (BMA 31/32, BMA 33/34 or BMAVAR 31/32, BMAVAR 33/34 option)

Once it has been switched on, the motor starts after the control knob corresponding to the desired direction of rotation has been pressed for one second.

The speed is only adjusted with the local control knob.

4.4 - Setting the speed

4.4.1 - External reference

Adjust the speed reference using the chosen reference (0/10 V or 4/20 mA).

4.4.2 - Control knob options (B 31/32 or B 33/34) and remote potentiometer option

Adjust the speed reference using the control knob or the 10 k Ω remote potentiometer.

4.4.3 - Internal speed control option (CVI VMA 31/32 or CVI BMA 33/34)

Adjust the speed reference using the Int. Spd. potentiometer. Adjust the Max. Spd. or Min. Spd. potentiometers if it is not possible to reach the desired speed.

VARMECA 30

Variable speed motor or geared motor

FAULTS-DIAGNOSTICS

5 - FAULTS-DIAGNOSTICS

Information relating to the status of the VARMECA 30 is provided by two indicator lamps located on the local control options (B 31/32 or B 33/34, BMA 31/32 or BMA 33/34, BMAVAR 31/32 or BMAVAR 33/34, CVI VMA 31/32 or CVI VMA 33/34 options), or by the internal LED in VMA 31/32.

Colour and state of indic. lamp	VARMECA status	Checks to be performed
Steady green	No trip Mains present	
Flashing green	Current limiting	<ul style="list-style-type: none"> • Check that the motor is not overloaded or stalled
Flashing red	IGBT temperature alarm Motor overload Braking resistor option overload	<ul style="list-style-type: none"> • Check that air is able to circulate around the motor fins and VARMECA casing • The motor is overloaded: check the motor current using a clamp ammeter • Check that the deceleration ramp is long enough for applications with high inertia
Steady red	<ul style="list-style-type: none"> • Short-circuit of a motor winding • Locked motor rotor • Faulty insulation of a winding • I²t overheating • Internal fault • Undervoltage • Overvoltage 	<ul style="list-style-type: none"> • Check that no incident has occurred • Switch off and then on again to clear the fault. • Check the mains voltage • Check that the deceleration ramp is long enough for applications with high inertia • If the fault remains, consult LEROY-SOMER

The fault is cleared by switching off the VARMECA 30 or by opening/closing the connection between terminals 12: ENA and 11: +24 V (VMA 31/32) or SDI1 and SDI2 (VMA 33/34).

6 - MAINTENANCE

 **All work relating to installation, commissioning and maintenance must be carried out by experienced, qualified personnel.**

• Before carrying out any work, disconnect and lock the VARMECA 30 power supply circuit and wait 2 minutes for the capacitors to discharge.

6.1 - Care

No special care is required on the VARMECA 30, apart from the regular removal of dust from the fan grille and the cooling fins located at the bottom of the casing.

Do not dismantle the VARMECA 30 while it is still under guarantee, as this would then immediately become null and void.

CAUTION:

Certain components which are sensitive to electrostatic discharge may be destroyed simply by touching them.

Do not leave any metal object in the connection area, as this could cause a short-circuit.

6.2 - Measurements

6.2.1 - General

The input voltages can be measured using ordinary instruments.

The motor current IS NOT MEASURED ON THE VARMECA 30 POWER SUPPLY (L1, L2, L3).

It is measured using an ordinary clamp ammeter on one of the wires which goes into the motor terminal block.

6.2.2 - Procedure for measuring the motor current on VMA 31/32 (if the motor wire loop is inaccessible)

- Open the VARMECA 30 power supply circuit and lock it.
- Wait 2 minutes for the capacitors to discharge (for the single-phase range).
- Open the cover of the VARMECA 30.
- Open the connection between terminals SDI1 and SDI2 (VMA 33/34) or 11 and 12 (VMA 31/32).
- Remove the TORX + slot type screws from the protection plate above the motor terminals.
- Pass the longest motor wire along the side of the protection circuit.
- Replace the protection plate and fasten it.
- Pass the clamp ammeter through the motor wire loop.
- Remake the connection between terminals SDI1 and SDI2 (VMA 33/34) or 11 and 12 (VMA 31/32).

VARMECA 30

Variable speed motor or geared motor

OPERATING EXTENSIONS

7 - OPERATING EXTENSIONS

7.1 - Speed control knob option (B 31/32 or B 33/34)

The speed is set using a knob with graduations from 15 to 100%.

- With 2 indicator lamps.
- Connected on the P2 connector (VMA 31/32) or directly on the control terminals (VMA 33/34)



7.2 - Control knob with integrated run-stop control option (BMA 31/32 or BMA 33/34)

In addition to speed control, a run button and a stop button make it possible to control the VARMECA 30 locally, once it has been switched on, as required. For a run command to be taken into account, **the button must be held down for one second.**

- With 2 indicator lamps.
- Connected on the P2 connector (VMA 31/32) or directly on the control terminals (VMA 33/34).
- Do not wire the shunt between terminals 8-11 and/or 9-11 (VMA 31/32).



7.3 - Control knob with forward/reverse/stop control option (BMAVAR 31/32 or BMAVAR 33/34)

In addition to speed control, a forward button, a reverse button and a stop button make it possible to control the VARMECA 30 locally, once it has been switched on, as required. For a run command to be taken into account, the button must be held down for one second.

- With 2 indicator lamps.
- Connected on the P2 connector (VMA 31/32) or directly on the control terminals (VMA 33/34).
- Do not wire the shunt between terminals 8-11 and/or 9-11 (VMA 31/32).



7.4 - Internal speed control option (CVI VMA 31/32 or CVI VMA 33/34)

The speeds are set on potentiometers which are accessible once the cover has been removed.

- ① Min.Spd potentiometer: calibration of the minimum speed.
 - ② Int.Spd potentiometer: speed control which replaces control via the control knob.
 - ③ Max.Spd potentiometer: calibration of the maximum speed.
- There are also 2 indicator lamps.

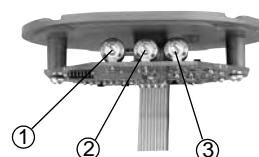

Note: With this option, do not wire up terminal AD11.

VARMECA 30

Variable speed motor or geared motor

OPERATING EXTENSIONS

7.5 - IP 65 braking resistor option (RF100 – RF200 – RF600)

For operation in 4 quadrants and energy dissipation, resistors can be fixed directly onto the VARMECA casing. **In this case, the jumper between terminals FI and R- should be removed (VMA 31 and 32).**



	RF 100			RF 200		
	P peak kW	P thermal kW	Value Ω	P peak kW	P thermal kW	Value Ω
VMA 31T/TL	3.2	0.1	200	3.2	0.2	200 (2x100 in series)
VMA 31M	0.8			0.8		
VMA 32T/TL	3.2			3.2		
VMA 32M	0.8			0.8		
RF 600						
	P peak kW	P thermal kW	Value Ω			
VMA 33/34T/TL	12.8	0.6	50	200 (2x100 in parallel)		

External resistors with greater thermal power can be used, provided that the minimum ohmic value of 180 Ω (RF 100 – RF 200) or 50 Ω (RF 600) is respected.

7.6 - IP 20 external braking resistor option (RF - BRR - 800 - 200)

	P peak kW	P thermal kW	Ω value
VMA 31/32T-TL	3.2	0.8	200
VMA 31/32M	0.8		

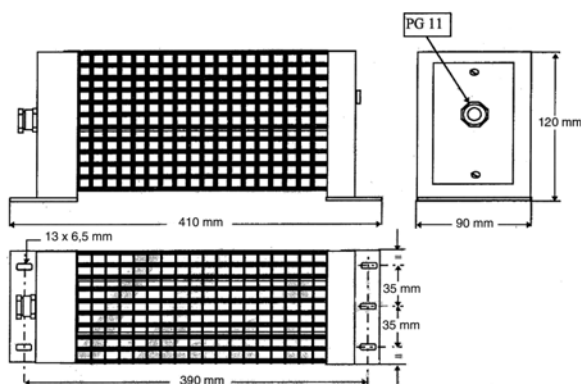

7.7 - Power supply and electromechanical brake control option (SO VMA 31/32)

The motor must be fitted with an FCR brake adapted for the VARMECA 31/32.

The brake has a built-in power supply. The brake is released as soon as the run command is enabled. The brake is engaged after a stop command, at the end of the deceleration ramp or on disconnection of the power supply.

7.8 - Additional I/O interface and sequential brake control option (ESFR VMA 31/32)

The brake has a built-in power supply. The brake is controlled according to a sequence which can be adjusted using the VARMECA parameters.

7.9 - Additional I/O interface and sequential brake control option (ESFR VMA 33/34)

The brake has a built-in power supply. The brake is controlled according to a sequence which can be adjusted using the VARMECA parameters. See VARMECA 30 parameter-setting manual.

7.10 - Fieldbus options (not available for VMA32 M)

The interface card is mounted inside the VARMECA casing.

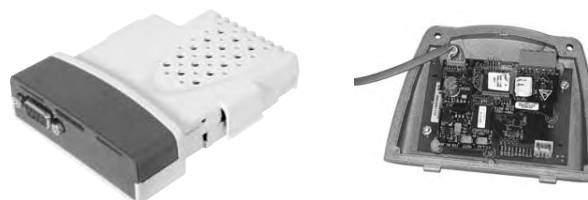

Protocols supported:
PROFIBUS DP - INTERBUS S
DEVICENET - CAN OPEN

7.11 - Encoder feedback option (COD VMA 33/34)

VMA33/34 only: Please contact Leroy-Somer.

en

VARMECA 30

Variable speed motor or geared motor

OPERATING EXTENSIONS

7.12 - Parameter-setting console option (PX LCD)

The console option provides access to the drive internal settings (terminal block configuration, ramp, speed and PI settings, etc).

See VARMECA 30 parameter-setting manual.

Description of the option:

1 PX LCD console

1 cable L = 3 m



PX LCD parameter-setting console

7.13 - Parameter-setting software option (SOFTVMA 30)

This option provides access to the drive internal settings from a PC. The software is compatible with WINDOWS 95, 98, NT, 2000, XP and subsequent versions.

See VARMECA 30 parameter-setting manual.

Description of the option:

1 CD ROM

1 cable, L = 3 m

7.14 - Operator display option (PAD VMA 30)

The VARMECA 30 operator display consists of a display unit, three control buttons and three parameter-setting keys. Please contact Leroy-Somer.

7.15 - XPress Key (PX Key)

7.15.1 - General

The XPress Key option is used to save a copy of all the VARMECA 30 parameters so that they can be duplicated very simply in another drive.



7.15.2 - Setting drive parameters with XPress Key

- Connect XPress Key to the serial port via a RJ45 connector.
- With the drive locked, press the "Key" button for a first time. Confirm the transfer of parameters into the drive by pressing the "Key" button a second time.

CAUTION:

If confirmation is not received within 10 seconds, the procedure is cancelled.

VARMECA 30

Variable speed motor or geared motor

OPERATING EXTENSIONS

7.16 - EMC filter (FLT VMA33/FLT VMA34)

VARMECA 33/34 drives conform to drive standard EN 61800-3 because of the EMC filter which can be integrated in the front of the VARMECA 30 casing.

7.16.1 - Dimensions

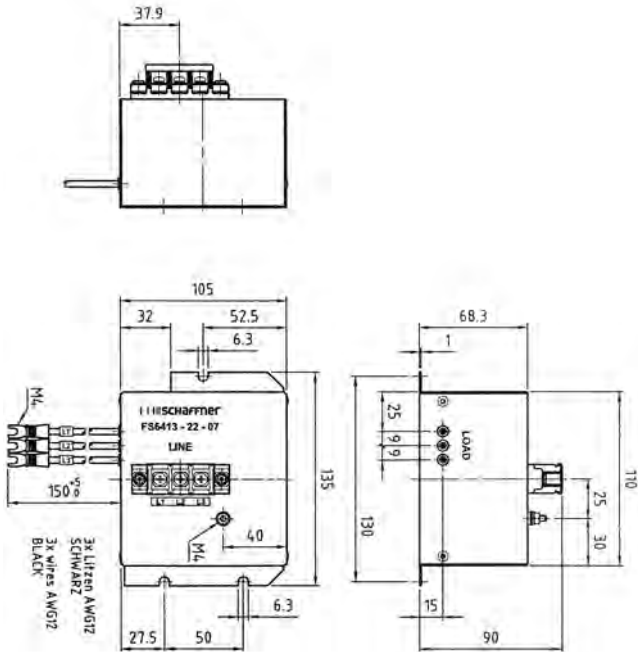

7.16.2 - Connection

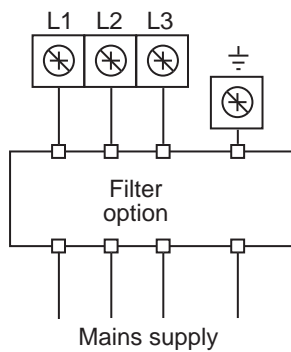

7.17 - EMC filter option (FLT VMA 31M)

The filter is mounted in the VMA 31M casing. The VARMECA then conforms to the requirements for residential environments.

7.18 - EMC filter option (FLT VMA 31/32)

The filter is mounted in the VMA 31/32 TL/T casing. The VARMECA then conforms to the requirements for residential environments.



VARMECA 30

Variable speed motor or geared motor

NOTES